



Technical Catalogue



# FTSW/H Series

Twin Screw Pump

## Using Range

Twin-screw pumps are designed to transfer a wide range of clean liquids, including low- and high-viscosity media without solid particles. They provide excellent reliability and stable performance for both lubricating and non-lubricating fluids, as well as corrosive media and liquids containing entrained gas.

- Capacity: 0.5–2500 m<sup>3</sup>/h
- Pressure: 0.1–6.0 MPa
- Viscosity: 0.5–100,000 mm<sup>2</sup>/s
- Temperature: -30°C to 300°C

## Using Fields

**Oil Industry :** Transfer of lubricating oil, crude oil, residual oil, heavy oil, bitumen (pitch), diesel fuel, gasoline, and other petroleum products.

**Shipbuilding Industry :** Transfer of light and heavy fuel oil, waste oil, dirty oil, sludge, and oily bilge sludge.

Also suitable as a booster pump and ballast pump.

**Chemical Industry :** Transfer of acids, alkalis, salt solutions, resins, glycerin, paraffin wax, cosmetic emulsions, and other chemical fluids. Also suitable for bottle filling applications.

**Paint Industry :** Transfer of printing ink, pigments, paints, varnishes, and coatings.

**Food Industry :** Transfer of alcohol, beverages, honey, sugar syrup, toothpaste, milk, cream, soy sauce, animal fats, vegetable oils, chocolate, and other high-viscosity food products.

**Storage & Transportation :** Loading and unloading petroleum products from storage tanks, terminals, and oil tankers.

## Features

The specially designed suction and discharge ports enable the pump casing to retain sufficient liquid when the pump is stopped. As a result, the twin screw pump offers excellent self-priming performance, automatically evacuating air from the suction line and quickly establishing liquid flow without the need for manual priming.

The pump casing is equipped with a built-in relief valve of a specially designed construction. When the discharge pressure exceeds the preset operating pressure, the relief valve opens automatically, allowing part of the pumped liquid to bypass back to the suction side or return to the storage tank. This protects the pump from excessive pressure, reduces the required driving torque, and ensures safe operation under all operating conditions.

Externally mounted, independently lubricated synchronous timing gears transmit torque from the drive screw to the idler screw, ensuring precise synchronization without metal-to-metal contact between the screw rotors.

This non-contact design minimizes wear, provides excellent reliability when handling a wide variety of media, and allows the pump to withstand short periods of dry running without damage.

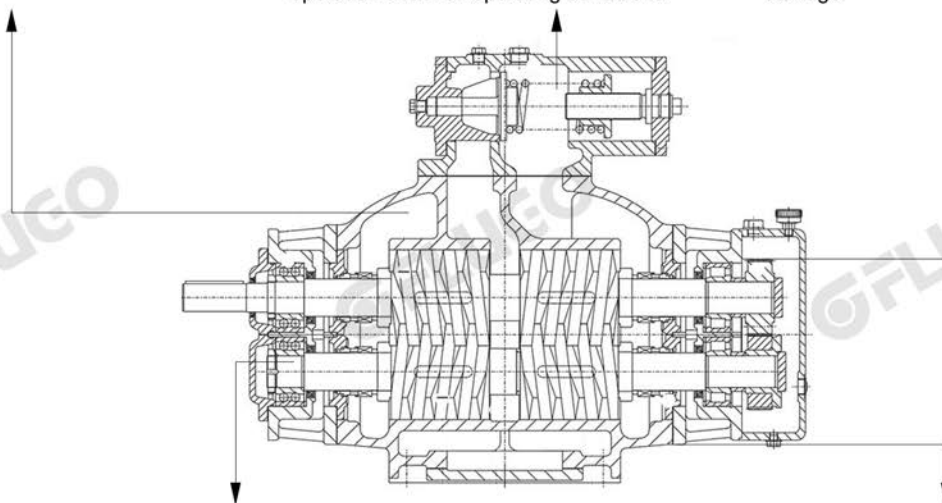



The specially profiled twin screws rotate within the pump casing to form a series of sealed chambers. As the screws rotate, these chambers move the liquid smoothly and continuously in the axial direction from the suction port to the discharge port. Since the volume of each sealed chamber remains constant during operation, the pump delivers a continuous, non-pulsating flow.

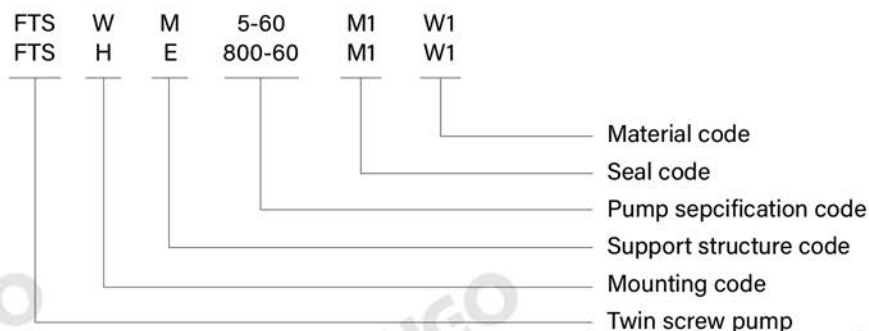

The twin screw pump is available with different casing designs to suit various operating temperatures and fluid applications.

## Type of pump and technical specification













According to the place of which screw spindle separate from ground, the mounting type of the pump has horizontal and vertical mounting.

FTSW FTSH	Horizontal mounting	Horizontal mounting is a general mounting, works conveniently and eases to maintain.		
FTSV	Vertical mounting	Vertical mounting is mainly used to place of small space, such as ship platform etc.		

E	Short-shaft and internal support structure		It is suitable to lubricate medium and the temperature $T \leq 100^{\circ}\text{C}$
M	middle-shaft and external support structure		It is suitable to various mediums and the temperature $T \leq 120^{\circ}\text{C}$ mechanical seal, oil seal
R	Long-shaft and external support structure		It is suitable to various mediums and the temperature $T \leq 300^{\circ}\text{C}$ mechanical seal, stuffing seal

## Seal Code

Code	Seal Type	Drawing	Range	Code	Seal Type	Drawing	Range
M0	Soft stuffing seal		$V \leq 100000 \text{mm}^2/\text{s}$ $T \leq 150^\circ\text{C}$	M4	Metal-pipe and high temperature seal		$V \leq 1000 \text{mm}^2/\text{s}$ $T = 150 \sim 300^\circ\text{C}$
M1	Single-end uneven and general seal		$V \leq 3000 \text{mm}^2/\text{s}$ $T = -20 \sim 120^\circ\text{C}$	M5	Double-end and uneven seal		$V \leq 10000 \text{mm}^2/\text{s}$ $T = -20 \sim 120^\circ\text{C}$
M2	Single-end, uneven and high-temperature seal		$V \leq 3000 \text{mm}^2/\text{s}$ $T = -20 \sim 120^\circ\text{C}$	M6	Shaft-covering and single-end seal		$V \leq 2000 \text{mm}^2/\text{s}$ $T \leq 120^\circ\text{C}$
M3	Single-end, uneven and high-temperature seal		$V \leq 2000 \text{mm}^2/\text{s}$ $T = -20 \sim 200^\circ\text{C}$	M7	Shaft-covering and double-end seal		$V \leq 10000 \text{mm}^2/\text{s}$ $T \leq 120^\circ\text{C}$
M8	Special and soft stuffing seal		$V \leq 1000 \text{mm}^2/\text{s}$ $100^\circ\text{C} \leq T \leq 300^\circ\text{C}$	MT	Special seal		It is decided according to the user's requirement

Since twin screw pumps are capable of handling a wide variety of chemically different fluids, the wetted parts must be manufactured from materials compatible with the pumped medium. To ensure optimum performance and service life, material selection is based on the customer's application and fluid characteristics. The table below lists the standard material options and material codes offered by our company. Additional material combinations are available as new products and applications continue to be developed.

Code	Pump Casing	Rotor	Shaft
W1	HT250	QT400-18	20CrMnTi
W2	HT250	ZCuSn10Pb1	20CrMnTi
W3	QT400-18	QT400-18	20CrMnTi
W4	QT400-18	38CrMoAl	20CrMnTi
W5	QT400-18	2Cr13	20CrMnTi
W6	ZG1Cr18Ni9Ti	0Cr18Ni9	0Cr17Ni4Cu4Nb
W7	ZG1Cr18Ni9Ti	0Cr18Ni12Mo2	0Cr17Ni4Cu4Nb
W8	CF-8M	316	0Cr17Ni4Cu4Nb
W9	CF-8M	316L	0Cr17Ni4Cu4Nb
W11	ZG25	QT400-18	20CrMnTi
W12	ZG25	ZCuSn10Pb1	20CrMnTi
W13	ZG25	38CrMoAl	20CrMnTi
W14	ZG25	38CrMoAl	0Cr17Ni4Cu4Nb
W15	ZG25	2Cr13	0Cr17Ni4Cu4Nb
W16	ZG25	2Cr13	20CrMnTi
W17	ZG25	1Cr18Ni9	20CrMnTi
W18	ZG25	1Cr18Ni9	0Cr17Ni4Cu4Nb
W19			
W20			
W21	ZG0Cr18Ni9	0Cr17Ni4Cu4Nb	0Cr17Ni4Cu4Nb
W22	ZG1Cr18Ni12Mo2	0Cr17Ni4Cu4Nb	0Cr17Ni4Cu4Nb
W23	ZG1Cr18Ni12Mo2	0Cr17Ni4Cu4Nb	0Cr17Ni4Cu4Nb
W24	CF-8M	316	0Cr17Ni4Cu4Nb
W25	CF-8M	316L	0Cr17Ni4Cu4Nb

### Note of Selecting Pump

- Select the appropriate pump construction according to the operating temperature and whether the pumped liquid is lubricating or non-lubricating.
- Select the pump speed according to the fluid viscosity at the operating temperature.  
As a general recommendation, for fluids with a viscosity of up to 1,000 mm<sup>2</sup>/s, a pump speed of 1,450 rpm is recommended.  
For viscosities between 1,000 and 1,500 mm<sup>2</sup>/s, the required NPSHr should be carefully checked.  
For viscosities exceeding 1,500 mm<sup>2</sup>/s, please consult our technical department for proper pump selection.
- Select the appropriate pump model according to the required flow rate and discharge pressure using the Twin Screw Pump Performance Table.
- Determine the required NPSHr from the NPSHr table according to the selected pump model, operating speed, and fluid viscosity.
- The selected pump is suitable only when:  
NPSHa > NPSHr  
If the available NPSHa is equal to or lower than the required NPSHr, select another pump model or reduce the operating speed.
- After selecting the pump, determine the required shaft power (P1) from the performance table according to the operating pressure and fluid viscosity.  
Select a motor whose rated power (P2) is equal to or greater than:  $P2 \geq K \times P1$   
where K is the service factor.

N1(KW)	N1≤5	5<N1≤10	10<N1≤50	5<N1≤100	N1>100
K	1.5	1.25	1.2	1.15	1.1

- After selecting both the pump and the motor, design the baseplate according to the dimensions and installation requirements of the complete pump set.

## FTSW-M

The leading features of FTSW  
Twin Screw Pump



1. The pump delivers a smooth, continuous, and pulse-free flow. The specially designed pump casing ensures complete sealing of the pumping chambers, resulting in excellent self-priming capability. The pump can also handle liquids containing entrained gas or air.
2. The specially designed hydraulic system provides outstanding suction performance with a very low NPSHr, ensuring reliable operation even under demanding suction conditions.
3. The pump is equipped with externally mounted, independently lubricated bearings, allowing it to handle both lubricating and non-lubricating fluids with excellent reliability.
4. Synchronous timing gears ensure precise synchronization of the screw rotors without metal-to-metal contact. This minimizes wear and allows the pump to tolerate short periods of dry running without damage.
5. Various construction options are available, including horizontal, vertical, and liner-type designs. With proper material selection, the pump can handle a wide range of clean liquids, from low- to high-viscosity media, including corrosive fluids, provided they are free of solid particles.
6. The suction port is located on the side of the pump, while the discharge port is positioned on the top. This compact arrangement minimizes installation space, making the pump particularly suitable for marine applications and other installations where space is limited.

△

### NPSHr table of pump

Size	Speed n=950r/min						Speed n=1450r/min					
	Viscosity mm <sup>2</sup> /s						Viscosity mm <sup>2</sup> /s					
	≤35	75	150	350	750	1500	≤35	75	150	350	750	1500
	NPSHr(m)											
2W2-12, 18, 24	1.6	1.6	1.6	1.6	1.6	1.6	1.6	1.6	1.7	1.7	1.7	1.8
2W2-36, 48	1.7	1.7	1.7	1.8	1.8	1.9	1.9	1.9	2.0	2.0	2.1	2.3
2W3-20, 28	1.6	1.6	1.6	1.6	1.6	1.6	1.6	1.6	1.7	1.7	1.7	1.8
2W3-40, 56	1.7	1.7	1.7	1.8	1.8	1.9	1.9	1.9	2.0	2.0	2.1	2.3
2W4-25, 34	1.6	1.6	1.6	1.7	1.7	1.7	1.7	1.7	1.7	1.8	1.8	1.9
2W4-50, 72	1.8	1.8	1.8	1.9	2.0	2.7	2.1	2.1	2.2	2.3	2.4	2.6
2W5-30, 40	1.6	1.7	1.7	1.7	1.8	1.8	1.8	1.8	1.8	1.9	1.9	2.0
2W5-60, 80	1.9	1.9	2.0	2.0	2.1	2.3	2.2	2.3	2.1	2.6	2.7	3.0
2W6-38, 50	1.7	1.7	1.7	1.8	1.8	1.9	1.9	1.9	1.9	2.0	2.1	2.2
2W6-75, 96	2.0	2.1	2.2	2.3	2.4	2.6	2.6	2.7	2.8	3.0	3.3	3.6
2W7-43, 56	1.7	1.8	1.8	1.8	1.9	2.0	1.9	2.0	2.0	2.1	2.2	2.4
2W7-85, 112	2.2	2.2	2.3	2.4	2.6	2.8	2.8	3.0	3.1	3.4	3.7	4.1
2W8-50, 67	1.8	1.8	1.8	1.9	2.0	2.1	2.1	2.1	2.2	2.3	2.4	2.6
2W8-100, 128	2.4	2.4	2.5	2.7	2.9	3.2	3.3	3.4	3.6	4.0	4.0	4.8
2W9-80, 100	1.8	1.8	1.8	1.9	2.0	2.1	2.1	2.1	2.2	2.3	2.4	2.6
2W9-128, 150	2.4	2.4	2.5	2.7	2.9	3.2	3.3	3.4	3.6	4.0	4.0	4.8
2W10-80, 100	1.8	1.8	1.8	1.9	2.0	2.0	2.0	2.1	2.1	2.2	2.4	2.5
2W10-128, 150	2.1	2.2	2.2	2.4	2.5	2.7	2.7	2.8	2.9	3.2	3.5	3.8
2W11-128, 160	2.0	2.0	2.2	2.2	2.5	2.5	2.2	2.2	2.5	2.5	3.0	3.0
2W11-176, 192, 250	2.4	2.4	2.6	2.6	3.0	3.0	2.5	2.5	3.0	3.0	3.5	3.8

**FTSW Performance Parameters**

The performance table of main technique

Speed n=1450r/min

Size	ΔP (bar)	Viscosity (mm <sup>2</sup> /s)															
		1		15		35		75		150		350		750		1500	
		m <sup>3</sup> /h	KW	m <sup>3</sup> /h	KW	m <sup>3</sup> /h	KW	m <sup>3</sup> /h	KW	m <sup>3</sup> /h	KW	m <sup>3</sup> /h	KW	m <sup>3</sup> /h	KW	m <sup>3</sup> /h	KW
FTSW2-12	2	3.4	0.2	3.5	0.27	3.6	0.27	3.8	0.28	3.8	0.31	4	0.34	4.2	0.36	4.6	0.4
	4	3.2	0.5	3.3	0.54	3.4	0.54	3.6	0.56	3.6	0.61	3.8	0.67	4	0.73	4.4	0.78
	6	3.2	0.7	3.3	0.8	3.4	0.8	3.6	0.84	3.6	0.93	3.8	1	4	1.1	4.4	1.2
	8	3	0.9	3.1	1	3.2	1.2	3.4	1.1	3.4	1.21	3.6	1.32	3.8	1.43	4	1.54
	10	3	1.1	3.1	1.2	3.2	1.2	3.4	1.3	3.4	1.4	3.6	1.6	3.8	1.7	4	1.8
	12	2.8	1.3	2.9	1.4	3	1.4	3.2	1.5	3.2	1.7	3.4	1.8	3.6	2	3.8	2.1
	14	2.7	1.4	2.8	1.5	2.9	1.5	3.1	1.7	3.1	1.9	3.3	2	3.5	2.2	3.7	2.4
	16	2.6	1.6	2.7	1.7	2.8	1.7	3	1.9	3	2.1	3.2	2.3	3.4	2.5	3.6	2.7
	18	2.5	1.7	2.6	1.8	2.7	1.8	2.9	2	2.9	2.2	3.1	2.4	3.3	2.7	3.5	2.9
	20	2.4	1.9	2.5	2	2.6	2	2.8	2.1	2.8	2.3	3	2.5	3.2	2.8	3.4	3
FTSW2-18	2	4.8	0.3	4.9	0.4	5	0.4	5.2	0.4	5.2	0.5	5.4	0.5	5.6	0.6	6	0.6
	4	4.6	0.6	4.7	0.7	4.8	0.7	5	0.8	5	0.9	5.2	1	5.4	1.1	5.8	1.2
	6	4.4	0.9	4.5	1	4.6	1	4.8	1.1	4.8	1.2	5	1.3	5.2	1.5	5.6	1.6
	8	4.2	1.2	4.3	1.3	4.4	1.3	4.6	1.4	4.6	1.6	4.8	1.7	5	1.9	5.4	2
	10	3.8	1.4	3.9	1.5	4	1.5	4.4	1.6	4.4	1.8	4.6	1.9	4.8	2.1	5.2	2.3
	12	3.4	1.7	3.5	1.8	3.6	1.8	4.2	2	4.2	2.2	4.4	2.4	4.6	2.6	5	2.8
	14	3.2	2	3.3	2.1	3.4	2.1	4.1	2.3	4.1	2.5	4.3	2.7	4.5	3	4.9	3.1
	16	3	2.3	3.1	2.4	3.2	2.4	4	2.5	4	2.8	4.2	3	4.4	3.3	4.8	3.5
	18	2.8	2.6	2.9	2.7	3	2.7	3.9	2.7	3.9	3	4.1	3.3	4.3	3.6	4.7	3.9
	20	2.6	2.8	2.7	2.9	2.8	2.9	3.8	3	3.8	3.3	4	3.6	4.2	3.9	4.6	4.2
FTSW2-24	2	5.6	0.3	5.7	0.4	5.8	0.4	6.2	0.5	6.2	0.6	6.6	0.6	7	0.7	7.6	0.7
	4	5.4	0.9	5.5	1	5.6	1	6	1	6	1.1	6.4	1.2	6.8	1.3	7.4	1.4
	6	5.2	1.2	5.3	1.3	5.4	1.3	5.8	1.4	5.8	1.6	6.2	1.7	6.6	1.8	7.2	2
	8	5	1.6	5.1	1.7	5.2	1.7	5.6	1.8	5.6	2	6	2.2	6.4	2.4	7	2.6
	10	4.8	1.9	4.9	2	5	2	5.4	2.1	5.4	2.3	5.8	2.6	6.2	2.8	6.8	3
	12	4.6	2.2	4.7	2.3	4.8	2.3	5.2	2.4	5.2	2.7	5.6	2.9	6	3.2	6.4	3.4
	14	4.4	2.5	4.5	2.6	4.6	2.6	5	2.8	5	3	5.4	3.3	5.8	3.6	6.2	3.8
	16	4.2	2.8	4.3	2.9	4.4	2.9	4.8	3	4.8	3.3	5.2	3.6	5.6	3.9	6	4.2
	18	4	3.1	4.1	3.2	4.2	3.2	4.6	3.3	4.6	3.6	5	3.9	5.4	4.2	5.8	4.6
	20	3.8	3.3	3.9	3.4	4	3.4	4.4	3.5	4.4	3.9	4.8	4.2	5.2	4.6	5.6	4.9
FTSW2-36	2	8.8	0.6	8.9	0.7	9	0.7	9.4	0.8	9.4	0.9	9.8	1	10.4	1.1	11	1.2
	4	8.4	1.2	8.5	1.3	8.6	1.3	9	1.4	9	1.6	9.4	1.7	9.8	1.9	10.4	2
	6	8	1.8	8.1	1.9	8.2	1.9	8.6	2	8.6	2.2	9	2.4	9.6	2.6	10.2	2.8
	8	7.6	2.2	7.7	2.4	7.8	2.4	8.2	2.5	8.2	2.8	8.6	3	9.2	3.3	9.8	3.5
	10	7.2	2.8	7.3	2.9	7.4	2.9	7.8	3	7.8	3.6	8.2	3.6	8.8	3.9	9.4	4.2
	12	7	3.4	7.1	3.5	7.2	3.5	7.6	3.6	7.6	4	8	4.4	8.6	4.7	9.2	5
	14	6.8	3.9	6.9	4	7	4	7.4	4	7.4	4.5	7.8	5	8.4	5.4	9	5.8
	16	6.6	4.3	6.7	4.4	6.8	4.4	7.2	4.5	7.2	5	7.6	5.5	8.2	6	8.8	6.5
	18	6	4.5	6.1	4.7	6.2	4.7	6.8	4.7	6.8	5.3	7.3	5.7	7.9	6.3	8.6	6.7
	20	5.4	4.8	5.5	4.9	5.6	4.9	6.4	5	6.4	5.5	7	6	7.6	6.5	8.4	7
FTSW2-48	2	12.8	0.9	12.9	1	13	1	13.4	1.1	13.4	1.2	14	1.3	14.6	1.4	15.4	1.5
	4	12.4	1.8	12.5	1.9	12.6	1.9	13	2	13	2.2	13.6	2.4	14.2	2.6	15	2.8
	6	12	2.8	12.1	2.9	12.2	2.9	12.6	3	12.6	3.3	13	3.6	13.6	3.9	14.4	4.2
	8	11.2	3.5	11.3	3.6	11.4	3.6	11.8	3.7	11.8	4.1	12.4	4.5	13	4.8	13.6	5.2
	10	10.8	4.3	10.9	4.4	11	4.4	11.4	4.5	11.4	5	12	5.5	12.6	6	13.2	6.5
	12	10.4	4.9	10.5	5	10.6	5	11	5.1	11	5.6	11.6	6.1	12.2	6.6	13	7.2
	14	9.9	5.6	10	5.6	10.1	5.6	10.6	5.7	10.6	6.3	11.2	6.9	11.8	7.5	12.7	8.1
	16	9.4	6.2	9.5	6.3	9.6	6.3	10.2	6.4	10.2	7.1	10.8	7.7	11.4	8.4	12.4	9
	18	8.6	6.5	8.7	6.6	8.8	6.6	9.6	6.7	9.6	7.4	10.2	8.1	10.8	8.7	11.7	9.4
	20	7.8	6.8	7.9	6.9	8	6.9	9	7	9	7.7	9.6	8.4	10.2	9.1	11	9.8

## FTSW Performance Parameters

The performance table of main technique

Speed n=1450r/min

Size	ΔP (bar)	Viscosity (mm <sup>2</sup> /s)															
		1		15		35		75		150		350		750		1500	
		m <sup>3</sup> /h	KW	m <sup>3</sup> /h	KW	m <sup>3</sup> /h	KW	m <sup>3</sup> /h	KW	m <sup>3</sup> /h	KW	m <sup>3</sup> /h	KW	m <sup>3</sup> /h	KW	m <sup>3</sup> /h	KW
FTSW3-20	2	7.7	1.7	8	2	8.2	2.5	8.4	3	8.5	3.6	8.6	3.6	8.7	5.8	8.8	6.1
	4	6.9	2.2	7.4	2.6	7.7	3	8	3.5	8.2	4.2	8.4	5.2	8.5	6.4	8.6	7.1
	6	6.1	2.7	6.8	3.1	7.2	3.5	7.7	4.1	7.9	4.7	8.2	5.7	8.4	6.9	8.5	7.7
	8	5.4	3.2	6.3	3.6	6.9	4	7.3	4.6	7.7	5.2	8	6.2	8.2	7.4	8.4	8.2
	10	4.8	3.8	5.8	4.1	6.5	4.6	7	5.1	7.4	5.7	7.8	6.7	8.1	7.9	8.3	8.7
	12	4.3	4.5	5.4	4.7	6.1	5.1	6.8	5.6	7.2	6.3	7.6	7.3	7.9	8.5	8.2	9.2
	14	3.9	5.3	4.9	5.2	5.8	5.6	6.5	6.2	7	6.8	7.5	7.8	7.8	9	8	9.8
	16	3.2	5.1	4.5	5.7	5.6	6.1	6.3	6.7	6.9	7.3	7.4	8.3	7.7	9.5	8	10.3
	18	2.5	6	4.2	6.3	5.4	6.7	6.1	7.2	6.7	7.8	7.2	8.8	7.6	10	7.9	10.8
	20			3.8	7	5.1	7.3	5.9	7.7	6.5	8.4	7.1	9.4	7.5	10.6	7.8	11.3
	22					4.7	7.8	5.7	8.3	6.3	8.9	7.0	9.9	7.4	11.1	7.7	11.9
	24							5.5	8.9	6.1	9.5	6.8	10.4	7.3	11.6	7.6	12.4
FTSW3-28	2	10.5	1.9	10.9	2.3	11.2	2.8	11.4	3.3	11.5	4	11.7	5.1	11.8	6.4	11.9	7.2
	4	9.4	2.7	10	3.1	10.5	3.5	10.9	4.1	11.1	4.8	11.4	5.8	11.6	7.1	11.7	7.9
	6	8.4	3.4	9.3	3.8	9.9	4.2	10.4	4.8	10.8	5.5	11.1	6.5	11.3	7.8	11.5	8.6
	8	7.5	4.1	8.6	4.5	9.3	4.9	10	5.5	10.4	6.2	10.8	7.2	11.1	8.5	11.3	9.4
	10	6.7	4.9	8	5.2	8.8	5.6	9.6	6.2	10.1	6.9	10.6	8	11	9.2	11.2	10.1
	12	6	5.8	7.3	5.9	8.3	6.3	9.2	6.9	9.8	7.6	10.4	8.7	10.8	9.9	11.1	10.8
	14	5.1	6.2	6.8	6.7	7.9	7	8.8	7.6	9.5	8.3	10.2	9.4	10.6	10.7	10.9	11.5
	16			6.4	7.6	7.5	7.7	8.6	8.3	9.4	9	10	10.1	10.5	11.4	10.9	12.2
	18					7	8.5	8.4	9.1	9.1	9.7	9.9	10.8	10.4	12.1	10.7	12.9
20							7.8	9.7	8.9	10.4	9.7	11.5	10.2	12.8	10.6	13.6	
FTSW3-40	2	15.9	2.4	16.4	2.8	16.7	3.2	17	3.9	17.2	4.6	17.4	5.7	17.5	7.1	17.6	8
	4	14.4	3.4	15.3	3.8	15.9	4.3	16.3	4.9	16.7	5.7	17	6.8	17.2	8.1	17.3	9
	6	13.2	4.5	14.4	4.9	15.1	5.3	15.7	6	16.2	6.7	16.6	7.8	16.9	9.2	17.1	10.1
	8	12.1	5.5	13.5	5.9	14.1	6.4	15.2	7	15.8	7.8	16.3	8.9	16.7	10.2	16.9	11.1
	10	11.1	6.7	12.7	7	13.8	7.4	14.7	8	15.4	8.8	16	9.9	16.4	11.3	16.7	12.2
	12	10.2	8.1	11.9	8.3	13.2	8.5	14.2	9.1	15	9.8	15.7	11	16.2	12.3	16.6	13.2
	14			11.2	9.8	12.6	9.7	13.8	10.2	14.6	10.9	15.4	12	16	13.4	16.4	14.3
	16					12.1	11.1	13.4	11.4	14.4	11.9	15.2	13.1	15.9	14.4	16.3	15.3
FTSW3-56	2	22.3	2.9	23	3.4	23.4	3.9	23.8	4.6	24.1	5.4	24.3	6.7	24.5	8.2	24.6	9.1
	4	20.3	4.4	21.5	4.9	22.3	5.4	22.9	6.1	23.4	6.9	23.8	8.1	24.1	9.6	24.3	10.6
	6	18.5	6.7	20.2	6.3	21.3	6.8	22.1	7.5	22.7	8.3	23.3	9.6	23.7	11.1	24	12.1
	8			18.9	8.1	20.4	8.6	21.4	9	22.2	9.8	22.9	11.1	23.4	12.6	23.7	13.6
	10							20.7	10.8	21.6	11.3	22.5	12.5	23.1	14	23.5	15
FTSW4-25	2	15.5	2.5	16.1	3	16.4	3.6	16.7	4.3	16.9	5.1	17.1	6.4	17.3	8	17.4	9
	4	14	3.6	14.9	4.1	15.5	4.6	16	5.3	16.4	6.1	16.7	7.4	17	9	17.1	10
	6	12.7	4.6	13.9	5.1	14.7	5.6	15.4	6.3	15.9	7.2	16.3	8.4	16.7	10	16.9	11.1
	8	11.5	5.7	13	6.1	14	6.7	14.8	7.4	15.4	8.2	16	9.5	16.4	11.1	16.7	12.1
	10	10.3	6.7	12.1	7.1	13.3	7.7	14.3	8.4	15	9.3	15.7	10.6	16.1	12.1	16.5	13.1
	12	9.2	7.7	11.3	8.2	12.7	8.7	13.8	9.5	14.6	10.3	15.4	11.6	15.9	13.2	16.3	14.2
	14	8.2	8.8	10.5	9.2	12	9.8	13.3	10.5	14.2	11.3	15.1	12.6	15.7	14.2	16.1	15.2
	16	7.3	10.1	9.7	10.3	11.7	10.8	13	11.5	14	12.4	14.9	13.7	15.6	15.2	16	16.3
	18	6.1	10.8	8.9	11.5	11.1	11.9	12.6	12.5	13.7	13.4	14.7	14.7	15.4	16.3	15.9	17.3
	20			8.2	12.8	10.6	12.9	12.2	13.6	13.4	14.5	14.4	15.8	15.2	17.3	15.7	18.3
	22					10.2	14	11.8	14.7	13	15.5	14.2	16.8	15	18.3	15.6	19.4
	24							11.4	15.7	12.7	16.5	13.9	17.8	14.8	19.4	15.4	20.4

**FTSW Performance Parameters**

The performance table of main technique

Speed n=1450r/min

Size	ΔP (bar)	Viscosity (mm <sup>2</sup> /s)															
		1		15		35		75		150		350		750		1500	
		m <sup>3</sup> /h	KW	m <sup>3</sup> /h	KW	m <sup>3</sup> /h	KW	m <sup>3</sup> /h	KW	m <sup>3</sup> /h	KW	m <sup>3</sup> /h	KW	m <sup>3</sup> /h	KW	m <sup>3</sup> /h	KW
FTSW4-34	2	21.6	3.1	22.2	3.6	22.7	4.2	23	5	23.3	5.9	23.5	7.3	23.7	9	23.8	10.2
	4	19.8	4.5	20.9	5	21.6	5.6	22.2	6.4	22.6	7.3	23	8.7	23.3	10.4	23.5	11.6
	6	18.3	5.9	19.7	6.4	20.7	7	21.5	7.8	22	8.7	22.6	10.2	22.9	11.9	23.2	13
	8	16.8	7.3	18.6	7.9	19.8	8.4	20.8	9.2	21.5	10.1	22.2	11.6	22.6	13.3	23	14.4
	10	15.5	8.7	17.6	9.3	19	9.8	20.2	10.6	21	11.6	21.8	13	22.3	14.7	22.7	15.8
	12	14.2	10.1	16.6	10.7	18.2	11.3	19.6	12.1	20.5	13	21.4	14.4	22.1	16.1	22.5	17.2
	14	13	11.6	15.7	12.1	17.5	12.7	19	13.5	20.1	14.4	21.1	15.8	21.8	17.5	22.3	18.7
	16	11.5	12.4	15.2	13.5	17.1	14.1	18.7	14.9	19.9	15.8	20.9	17.2	21.6	18.9	22.2	20.1
	18			14.1	14.2	16.5	15.5	18.2	16.3	19.4	17.2	20.6	18.7	21.4	20.4	22	21.5
	20				15.3	16.2	17.7	17.7	19.1	18.6	20.3	20.1	21.2	21.8	21.8	22.9	
FTSW4-50	2	32.2	4	33	4.6	33.6	5.3	34	6.2	34.4	7.3	34.7	9	34.9	10.9	35	12.3
	4	29.8	6.1	31.2	6.7	32.2	7.4	32.9	8.3	33.5	9.4	34	11	34.4	13	34.6	14.3
	6	27.8	8.2	29.7	8.8	30.9	9.5	32	10.4	32.7	11.5	33.4	13.1	33.9	15.1	34.3	16.4
	8	25.9	10.3	28.3	10.9	29.8	11.5	31.1	12.5	32	13.5	32.9	15.2	33.5	17.2	33.9	18.5
	10	24.1	12.3	26.9	13	28.7	13.6	30.3	14.6	31.4	15.6	32.4	17.3	33.1	19.3	33.6	20.6
	12			25.6	15	27.7	15.7	29.5	16.6	30.7	17.7	31.9	19.4	32.8	21.4	33.4	22.7
	14					26.8	17.8	28.7	18.7	30.2	19.8	31.5	21.5	32.4	23.4	33.1	24.8
	16							28.3	20.8	29.8	21.9	31.2	23.5	32.2	25.5	32.9	26.8
FTSW4-72	2	46.1	5.2	47.4	6	48.2	6.8	48.8	7.8	49.3	9.1	49.8	11.1	50.1	13.4	50.3	14.9
	4	42.7	8.2	44.7	9	46.1	9.8	47.2	10.8	48.1	12.1	48.8	14	49.3	16.4	49.7	17.9
	6	40	9.6	42.4	12	44.3	12.8	45.8	13.8	46.9	15.1	48	17	48.7	19.4	49.2	20.9
	8			39.8	13.6	42.6	15.7	44.5	16.8	46	18.1	47.2	20	48.1	22.4	48.7	23.9
	10					38.5	17.8	43.3	19.8	44.9	21.1	46.5	23	47.5	25.4	48.3	26.9
FTSW5-30	2	28	5	28.7	6	29.1	7.2	29.4	8.7	29.7	10.5	30	13.3	30.1	16.7	30.3	18.8
	4	26.1	6.8	27.2	7.8	28	9	28.6	10.5	29	12.3	29.4	15.1	29.7	18.4	29.9	20.6
	6	24.5	8.6	26	9.6	27	10.7	27.8	12.3	28.4	14.1	29	16.8	29.4	20.2	29.7	22.4
	8	23	10.4	24.9	11.4	26.1	12.5	27.1	14.1	27.9	15.9	28.6	18.6	29	22	29.4	24.1
	10	21.6	12.2	23.8	13.2	25.3	14.3	26.5	15.9	27.4	17.7	28.2	20.4	28.7	23.7	29.1	25.9
	12	20.2	14	22.8	15	24.5	16.1	25.9	17.7	26.9	19.5	27.8	22.2	28.5	25.5	28.9	27.7
	14	19.8	16.1	21.8	16.8	23.7	17.9	25.3	19.5	26.4	21.3	27.4	24	28.2	27.3	28.7	29.5
	16	18.7	17.3	21.3	18.6	23.3	19.7	24.9	21.3	26.1	23.1	27.2	25.8	28	29.1	28.6	31.3
	18			20.8	20.6	22.6	21.5	24.4	23.1	25.7	24.8	26.9	27.6	27.8	30.9	28.4	33.1
	20					22	23.3	23.9	24.9	25.3	26.6	26.6	29.4	27.5	32.7	28.2	34.9
	22					21.4	25.3	23.4	26.7	24.9	28.4	26.3	31.2	27.3	34.5	28	36.7
	24							23	28.4	24.6	30.2	26.1	33	27.1	36.3	27.8	38.5
FTSW5-40	2	37.7	5.8	38.5	6.9	39	8.1	39.5	9.7	39.8	11.6	40.1	14.6	40.3	18.1	40.4	20.4
	4	35.4	8.2	36.8	9.3	37.7	10.5	38.4	12.1	38.9	14	39.4	17	39.8	20.5	40	22.8
	6	33.4	10.6	35.3	11.7	36.5	12.9	37.5	14.5	38.2	16.4	38.9	19.4	39.4	22.9	39.7	25.2
	8	31.6	13	33.9	14.1	35.4	15.3	36.6	16.9	37.5	18.8	38.4	21.8	39	25.3	39.4	27.6
	10	29.9	15.4	32.6	16.5	34.4	17.7	35.8	19.3	36.9	21.2	37.9	24.2	38.6	27.7	39.1	30
	12	28.3	18.2	31.4	18.9	33.4	20.1	35.1	21.7	36.3	23.6	37.4	26.6	38.3	30.1	38.8	32.4
	14	26.4	19.6	30.2	21.3	32.5	22.5	34.4	24.1	35.7	26	37	29	37.9	32.5	38.5	34.8
	16			29.1	24	31.9	24.8	34	26.5	35.4	28.4	36.8	31.4	37.7	34.9	38.4	37.2
	18					31.3	27.3	33.3	28.9	34.9	30.8	36.4	33.8	37.4	37.3	38.2	39.6
	20							32.9	31.3	34.4	33.2	36	36.2	37.1	39.7	37.9	42

## FTSW Performance Parameters

The performance table of main technique

Speed n=1450r/min

Size	ΔP (bar)	Viscosity (mm <sup>2</sup> /s)															
		1		15		35		75		150		350		750		1500	
		m <sup>3</sup> /h	KW	m <sup>3</sup> /h	KW	m <sup>3</sup> /h	KW	m <sup>3</sup> /h	KW	m <sup>3</sup> /h	KW	m <sup>3</sup> /h	KW	m <sup>3</sup> /h	KW	m <sup>3</sup> /h	KW
FTSW5-60	2	56.9	7.4	58	8.7	58.7	10	59.3	11.9	59.8	14	60.2	17.4	60.5	21.4	60.7	24
	4	53.8	11	55.7	12.3	56.9	13.6	57.9	15.5	58.6	17.6	59.3	21	59.8	25	60.1	27.6
	6	51.1	14.6	53.7	15.9	55.3	17.2	56.7	19.1	57.6	21.2	58.6	24.6	59.2	28.5	59.7	31.2
	8	48.5	19.4	51.8	19.5	53.8	20.8	55.5	22.7	56.7	24.8	57.9	28.2	58.7	32.1	59.2	34.8
	10	46	25.8	50	23.1	52.4	24.4	54.4	26.3	55.9	28.4	57.2	31.8	58.2	25.7	58.2	38.4
	12	43.7	26.5	48.3	27.4	51.1	28	53.4	29.8	55	32	56.6	35.3	57.5	39.3	58.5	42
	14			46.6	32.5	49.8	32.2	52.4	33.4	54.3	35.6	56	38.9	57.2	42.9	58.1	45.6
	16					48.1	34.5	51.4	37.4	53.8	39.2	55.6	42.5	57	46.5	57.9	49.1
FTSW5-80	2	74.6	9.1	76.4	10.5	77.6	12	78.6	14.1	79.3	16.5	79.9	20.2	80.4	24.6	80.7	27.6
	4	69.5	13.9	72.6	15.3	74.6	16.8	76.2	18.9	77.4	21.3	78.5	25	79.3	29.4	79.9	32.4
	6	64.7	21.2	69.2	20.1	71.9	21.6	74.2	23.6	75.8	26.1	77.3	29.8	78.4	34.2	79.1	37.2
	8			65.9	26.4	69.5	24.6	72.3	28.4	74.3	30.8	76.2	34.6	77.5	39	78.4	42
	10					67.2	32.2	70.5	33.2	72.9	35.6	75.1	39.4	76.5	43.8	77.7	46.8
FTSW6-38	2	53.7	6.6	54.6	7.6	55.2	8.7	55.7	10.3	56.1	12	56.4	14.8	56.7	18.1	56.8	20.3
	4	51.1	9.9	52.6	11	53.7	12.1	54.5	13.6	55.1	15.4	55.7	18.2	56.1	21.5	56.4	23.7
	6	48.8	13.3	50.9	14.3	52.3	15.4	54.5	17	54.3	18.8	55.1	21.5	55.6	24.8	56	27
	8	46.7	16.6	49.3	17.7	51	18.8	52.5	20.3	53.5	22.1	56.5	24.9	55.1	28.2	55.6	30.4
	10	44.8	20	47.1	21	49.9	22.2	51.6	23.7	52.8	25.5	53.9	28.3	54.7	31.6	55.3	33.8
	12	42.9	23.4	46.5	24.4	48.8	25.5	50.7	27.1	52.1	28.8	53.4	31.6	54.3	34.9	55	37.1
	14	41.1	27.4	45.1	27.8	47.7	28.9	49.9	30.4	51.4	32.2	52.9	35	53.9	38.3	54.7	40.5
	16	38.9	29.2	43.7	31.6	47.1	32.2	49.4	33.8	51.1	35.6	52.6	38.3	53.7	41.7	54.5	43.8
	18			41.3	33.1	46.2	35.6	48.7	37.1	50.5	38.9	52.2	41.7	53.4	45	54.2	47.2
	20					45.3	39.3	48	40.5	50	42.3	51.8	45.1	53.1	48.4	54	50.6
	22							47.3	43.9	49.4	45.6	51.4	48.4	52.7	51.7	53.7	53.9
24									48.9	49	51	51.8	52.4	55.5	53.5	57.3	
FTSW6-50	2	71.3	8	72.4	9.2	73.1	10.4	73.6	12.2	74	14.2	74.4	17.3	74.7	21	74.9	23.5
	4	68.4	12.4	70.2	13.6	71.3	14.9	72.3	16.6	73	18.6	73.6	21.7	74	25.5	74.4	27.9
	6	65.9	16.9	68.2	18	69.8	19.3	71.1	21	72	23	72.9	26.2	73.5	29.9	73.9	32.3
	8	63.5	21.3	66.5	22.5	68.4	23.7	70	25.4	71.2	27.5	72.2	30.6	73	34.3	73.5	36.8
	10	61.3	25.7	64.8	26.9	67.1	28.1	69	29.9	70.3	31.9	71.6	35	72.5	38.7	73.2	41.2
	12	59.2	31	63.2	31.3	65.8	32.6	68	34.3	69.6	36.3	71	39.4	72	43.1	72.8	45.6
	14	56.5	33.6	61.7	35.7	64.6	37	67.1	38.7	68.8	40.7	70.5	43.8	72.6	47.6	72.5	50
	16			60.2	40.7	64	41.4	66.5	43.1	68.4	45.1	70.2	48.3	71.6	52	72.3	54.5
	18					63.4	46.3	65.7	47.6	67.8	49.6	69.7	52.7	71	56.4	72	58.9
	20							64.9	52.5	67.2	54	69.2	57.1	70.6	60.8	71.7	63.3
	FTSW6-75	2	106.8	10.9	108.4	12.3	109.5	13.8	110.3	15.9	111	18.3	111.6	22	112	26.5	112.3
4		102.2	17.6	105	19	106.7	20.5	108.2	22.5	109.3	24.9	110.3	28.7	111	33.1	111.5	36
6		98.2	24.2	102	25.6	104.4	27.1	106.4	29.2	107.8	31.6	109.2	35.3	110.2	39.7	110.8	42.7
8		94.3	33.3	99.2	32.2	102.2	33.7	104.7	35.8	106.5	38.2	108.2	41.9	109.3	46.4	110.2	49.3
10				96.6	38.9	100.1	40.4	103.1	40.1	105.2	44.8	107.2	48.6	108.6	53	109.6	56
12						98.2	47	101.6	42.4	104	51.5	106.3	55.2	107.9	59.6	109	62.6
14								100.1	55.7	102.7	58.1	105.4	61.8	107.2	66.3	108.5	69.2
16										102.2	64.7	104.9	68.5	106.8	72.9	108.2	75.9
FTSW6-96	2	134.7	13.3	137.3	14.8	138.9	16.5	140.3	18.8	141.3	21.5	142.2	25.7	142.9	30.6	143.4	33.9
	4	127.6	21.7	131.9	23.3	134.6	25	137	27.3	138.7	30	140.2	34.2	141.3	39.1	142.1	42.4
	6	119	26.8	127.1	31.8	130.9	33.5	134.1	35.8	136.4	38.5	138.5	42.7	140	47.6	141.1	50.9
	8			121.3	35.2	127.2	38.7	131.4	44.3	134.2	47	136.9	51.1	138.7	56.1	140.1	59.4
	10							127.6	49.5	132.3	55.5	135.4	59.6	137.6	64.6	139.1	67.9

**FTSW Performance Parameters**

The performance table of main technique

Speed n=1450r/min

Size	ΔP (bar)	Viscosity (mm <sup>2</sup> /s)															
		1		15		35		75		150		350		750		1500	
		m <sup>3</sup> /h	KW	m <sup>3</sup> /h	KW	m <sup>3</sup> /h	KW	m <sup>3</sup> /h	KW	m <sup>3</sup> /h	KW	m <sup>3</sup> /h	KW	m <sup>3</sup> /h	KW	m <sup>3</sup> /h	KW
FTSW7-43	2	85.5	11.2	87	13	87.9	15.1	88.7	17.8	89.3	21.1	89.8	26.1	90.2	32.1	90.5	36.1
	4	81.5	16.5	83.9	18.4	85.5	20.4	86.8	23.2	87.8	26.4	88.7	31.5	89.3	37.5	89.8	41.4
	6	77.9	21.9	81.2	23.7	83.4	25.8	85.2	28.5	86.5	31.8	87.7	36.8	88.5	42.8	89.2	46.8
	8	74.7	27.2	78.8	29.1	81.4	31.1	83.7	33.9	85.3	37.1	86.8	42.2	87.8	48.2	88.6	52.1
	10	71.6	32.6	76.5	34.4	79.6	36.5	82.2	39.2	84.2	42.5	85.9	47.5	87.2	53.5	88.1	57.5
	12	68.7	37.9	74.3	39.8	77.9	41.8	80.9	44.6	83.1	47.8	85.1	52.9	86.5	58.9	87.6	62.8
	14	65.9	43.3	72.2	45.1	76.2	47.2	79.6	49.9	85	53.2	84.3	58.2	85.9	64.2	87.1	68.2
	16	62.3	47	71	50.5	75.3	52.5	78.9	55.3	84.5	58.5	83.9	63.6	85.6	69.6	86.8	73.5
	18	57.8	51.4	69.2	55.8	73.8	57.9	77.8	60.6	80.6	63.9	83.2	68.9	85.1	74.9	86.4	78.9
	20			67.4	61.2	72.5	63.2	76.7	66	79.7	69.2	82.6	74.3	84.6	80.3	86	84.2
	22					71.1	68.6	75.6	71.3	78.9	74.6	82	79.6	84.1	85.6	85.6	89.6
	24							74.6	76.7	78.1	79.9	81.3	85	83.6	81	85.2	94.9
FTSW7-56	2	111.4	13.4	113.3	15.4	114.5	17.7	115.5	20.7	116.3	24.3	117	29.9	117.5	36.5	117.8	40.9
	4	106.1	20.3	109.3	22.4	111.4	24.6	113.1	27.7	114.3	31.3	115.5	36.9	116.3	43.5	116.9	47.9
	6	101.5	27.3	105.8	29.4	108.6	31.6	110.9	34.7	112.6	38.3	114.2	43.8	115.3	50.4	116.1	54.8
	8	97.3	34.3	102.6	36.3	106.1	38.6	109	41.6	111.1	45.2	113	50.8	114.4	57.4	115.4	61.8
	10	93.3	41.2	99.6	43.3	103.7	45.5	107.1	48.6	109.6	52.2	111.9	57.8	113.5	64.4	114.7	68.8
	12	89.5	49.5	96.7	50.3	101.4	52.5	105.4	55.6	108.2	59.2	110.9	64.7	112.7	71.3	114	75.7
	14	84.7	56.3	93.8	58.4	99.3	59.5	103.7	62.5	106.9	66.1	109.8	71.7	111.9	78.3	113.4	82.7
	16			88.5	65.5	91.4	67.4	102.7	69.5	106.1	73.1	109.3	78.7	111.5	85.3	113.1	89.7
	18					81.8	75.2	101.8	77.3	105	80.1	108.4	85.6	110.8	92.2	112.5	96.6
	20							98.1	85	103.9	87	107.6	92.6	110.2	99.2	112	103.6
FTSW7-85	2	169	18.1	171.9	20.5	173.8	23.1	175.4	26.7	176.5	30.9	177.6	237.4	178.3	45.2	178.8	50.3
	4	160.9	28.7	165.8	31.1	168.9	33.7	171.6	37.3	173.5	41.5	175.3	48	176.5	55.8	177.4	60.9
	6	153.8	39.2	160.4	41.7	164.7	44.3	168.3	47.9	170.9	52.1	173.3	58.6	175	66.3	176.2	71.5
	8	147	53.5	155.5	52.2	160.8	54.9	165.3	58.5	168.5	62.6	171.5	69.2	173.6	76.9	175.1	82.1
	10			150.7	65.3	157.1	65.4	162.4	69	166.2	73.2	169.7	79.7	172.3	87.5	174	92.6
	12					153.5	77.9	159.7	79.6	164.1	83.8	168.1	90.3	171	98.1	173	103.2
	14							157.1	91.8	162	94.4	166.6	100.9	169.8	108.7	172.1	113.8
	16									160.9	105	165.7	111.5	169.1	119.2	171.5	124.4
FTSW7-112	2	223.4	22.6	227	25.4	229.4	28.5	231.4	32.7	232.8	37.5	234.1	45.1	235	54.1	235.7	60
	4	213.3	36.6	219.4	39.4	223.3	42.4	226.6	46.6	229	51.5	231.3	59.1	232.8	68	234	74
	6			212.7	53.3	218	56.4	222.5	60.5	225.8	65.4	228.8	89.9	230.9	81.9	232.4	87.9
	8			206.2	72.1	212.8	75.1	218.7	74.5	222.8	79.3	226.5	93	229.1	95.9	231	101.8
	10							215	91.7	219.9	93.3	224.4	100.8	227.5	109.8	229.7	115.8
FTSW8-50	2	154.1	21.6	155.9	25.6	157.1	29.9	158	35.7	158.8	42.5	159.4	53.1	159.5	65.7	160.2	74.1
	4	149	31.1	152.1	35	154	39.3	155.7	45.2	156.9	52	158	62.6	158.8	75.2	159.3	83.5
	6	144.6	40.5	148.7	44.5	151.4	48.8	153.6	54.6	155.3	61.4	156.8	72	157.8	84.6	158.6	93
	8	140.5	50	145.6	53.9	148.9	58.2	151.7	64	153.7	70.9	155.6	81.5	156.9	94.1	157.9	102.4
	10	136.6	59.4	142.7	63.4	146.7	67.6	150	73.5	152.3	80.3	154.6	90.9	156.1	103.5	157.2	111.9
	12	133	68.9	140	72.8	144.5	77.1	148.3	82.9	151	89.7	153.5	100.4	155.3	113	156.6	121.3
	14	129.5	78.3	137.3	82.3	142.4	86.5	146.6	92.4	149.7	99.2	152.6	109.8	154.6	122.4	156	130.8
	16	127.6	87.8	135.9	91.7	141.2	96	145.7	101.8	149	108.6	152	119.2	154.2	131.9	155.7	140.2
	18	124.6	97.2	133.6	101.1	139.4	105.4	144.4	111.3	147.9	118.1	151.2	128.7	153.5	141.3	155.1	149.7
	20			131.4	110.6	137.7	114.9	143	120.7	146.8	127.5	150.4	138.1	152.9	150.7	156.4	159.1
	22					136	124.3	141.7	130.2	145.8	137	149.6	147.6	152.3	160.2	154.2	168.5
	24							140.4	139.6	144.8	146.4	148.8	157	151.7	169.6	153.7	178

## FTSW Performance Parameters

The performance table of main technique

Speed n=1450r/min

Size	ΔP (bar)	Viscosity (mm <sup>2</sup> /s)															
		1		15		35		75		150		350		750		1500	
		m <sup>3</sup> /h	KW	m <sup>3</sup> /h	KW	m <sup>3</sup> /h	KW	m <sup>3</sup> /h	KW	m <sup>3</sup> /h	KW	m <sup>3</sup> /h	KW	m <sup>3</sup> /h	KW	m <sup>3</sup> /h	KW
FTSW8-67	2	206	26	209	30	210	34	211	40	212	47	213	59	214	72	217	81
	4	200	38	204	42	206	47	208	54	210	60	211	71	212	84	213	93
	6	194	51	199	55	203	59	206	66	208	73	210	84	211	97	212	106
	8	189	63	196	68	200	72	203	78	206	85	208	96	210	110	211	118
	10	184	76	192	80	197	85	201	91	204	98	207	109	209	122	210	131
	12	179	89	188	93	194	97	199	102	202	116	206	122	208	135	210	144
	14	175	101	185	106	191	110	197	116	201	123	204	134	207	148	209	156
	16			183	118	190	123	196	129	200	136	204	147	206	160	208	169
	18			180	131	188	134	144	141	198	149	203	160	206	173	208	182
					185	148	192	154	197	161	202	172	205	186	207	194	
FTSW8-100	2	305	33	309	37	312	42	314	48	316	56	318	68	319	82	320	91
	4	293	52	300	56	305	61	309	67	312	75	314	87	316	101	317	110
	6	283	70	292	75	299	80	304	86	308	94	311	106	314	120	316	129
	8	373	89	285	94	293	99	300	106	304	113	309	125	312	139	314	148
	10	264	108	278	113	288	117	295	124	301	132	306	144	310	158	312	167
	12			272	133	282	136	291	143	298	151	304	162	308	177	311	186
	14					277	155	287	162	295	169	301	181	306	195	310	205
	16							285	181	293	188	300	200	305	214	309	224
FTSW8-128	2	385	39	392	44	396	49	400	57	402	65	405	78	407	93	408	104
	4	366	63	277	68	385	73	391	84	395	89	400	102	403	118	405	128
	6	349	88	365	92	375	98	383	105	389	113	395	126	399	142	402	152
	8	334	112	353	117	366	122	376	129	384	134	391	150	396	166	399	176
	10			342	141	357	146	369	153	378	162	387	175	393	190	397	200
FTSW9-80	2	366	25	368	28	369	30	370	30	371	36	372	45	373	50	373	55
	4	348	48	350	52	352	56	354	57	355	68	356	80	357	93	357	105
	6	334	68	337	75	340	82	343	82	344	100	345	116	346	134	346	150
	8	318	85	322	96	327	106	331	106	332	127	333	148	334	170	334	190
	10	300	103	308	116	314	128	319	128	320	154	321	180	322	205	322	230
	12	278	118	290	133	300	147	307	147	308	177	309	206	310	235	310	265
	14	258	135	278	150	288	165	295	165	296	200	297	230	298	265	298	295
	16	239	155	265	165	276	182	284	182	284	220	285	255	286	290	289.7	325
	18			253	181	254	192	266	192	268	235	270	270	272	307	274	345
	20			242	198	230	195	244	195	247	240	250	273	253	312	256	350
	22					208	198	222	197	225	245	229	276	233	315	237	355
	24							185	200	190	250	195	280	200	320	205	360
FTSW9-100	2	466	32	468	35	469	37	470	37.6	471	46	472	55	473	63	473	70
	4	438	60	441	65	443	71	445	71.2	446	87	447	102	448	115	448	130
	6	424	83	425	95	428	103	430	103	431	125	432	145	433	165	433	185
	8	406	107	410	120	413	133	415	133	416	160	417	186	418	212	419	240
	10	388	128	393	145	397	160	400	160	401	195	402	225	404	256	406	285
	12	373	148	378	168	382	185	386	185	388	225	390	260	393	296	396	330
	14			352	186	362	206	368	206	370	250	373	290	377	330	380	370
	16			328	205	342	227	354	227	357	280	360	320	364	363	368	405
	18					324	244	338	244	341	300	344	342	347	390	350	440
	20					295	250	310	250	314	330	318	350	342	400	345	450
FTSW9-128	2	590	40	595	45	598	48	600	48	601	58	603	70	605	80	608	90
	4	565	75	570	85	572	92	574	92	575	112	577	130	580	150	582	165
	6	545	108	550	120	553	133	555	133	557	160	560	188	563	212	567	240
	8	525	138	530	155	533	172	536	172	538	208	540	240	543	275	547	310
	10	500	166	508	186	513	207	517	207	520	250	523	290	526	330	530	370
	12	480	192	486	216	493	240	498	240	500	290	503	336	506	384	510	430
	14			450	240	462	265	470	265	472	320	475	370	478	420	482	475
	16					420	290	430	290	432	350	435	406	438	460	442	520

**FTSW Performance Parameters**

The performance table of main technique

Speed n=1450r/min

Size	ΔP (bar)	Viscosity (mm <sup>2</sup> /s)															
		1		15		35		75		150		350		750		1500	
		m <sup>3</sup> /h	KW	m <sup>3</sup> /h	KW	m <sup>3</sup> /h	KW	m <sup>3</sup> /h	KW	m <sup>3</sup> /h	KW	m <sup>3</sup> /h	KW	m <sup>3</sup> /h	KW	m <sup>3</sup> /h	KW
FTSW9-150	2	710	50	715	55	718	60	720	60	722	72	725	85	728	100	732	110
	4	665	90	672	100	676	110	679	110	681	132	685	155	690	176	695	200
	6	610	125	622	140	630	155	635	155	637	186	640	218	645	248	650	280
	8	570	160	582	180	592	200	590	200	593	240	597	280	603	320	610	360
	10	500	192	520	216	535	240	545	240	550	294	555	336	562	380	570	430
FTSW9-160	2	760	60	765	63	768	67	770	68	772	81	775	94	778	105	782	117
	4	715	113	722	120	726	126	729	129	731	153	735	178	740	201	745	224
	6	660	157	672	167	680	177	685	181	687	216	690	250	695	283	700	315
	8	620	197	632	210	642	223	640	226	643	270	647	313	653	354	660	396
	10	550	218	570	236	585	254	595	262	600	314	605	365	612	415	620	465
FTSW10-80	2	553	55	561	62	565	70	569	81	572	94	573	110	575	125	576	138
	4	537	87	547	94	553	102	561	113	565	126	570	143	571	157	572	171
	6	521	119	535	127	544	135	554	146	560	159	564	175	567	189	569	203
	8	507	151	525	159	535	167	548	178	554	191	560	207	563	221	566	235
	10	493	184	514	191	527	199	542	210	550	223	556	239	560	253	563	267
	12	480	216	505	223	520	231	535	242	545	255	552	271	557	286	560	299
	14	467	248	494	255	512	264	529	275	540	287	548	304	554	318	557	332
	16	456	280	485	288	505	296	524	307	536	320	545	336	551	350	555	364
	18	445	313	478	320	498	328	518	339	530	352	542	368	548	382	552	396
	20			469	352	492	360	513	371	527	384	538	400	545	415	550	428
	22					485	392	509	403	523	416	535	433	542	447	547	461
	24							503	436	520	449	532	465	540	479	545	493
FTSW10-100	2	667	65	675	74	680	83	683	96	687	111	690	130	691	147	692	163
	4	645	104	658	113	667	122	673	135	679	150	683	169	686	186	688	202
	6	625	143	643	151	655	161	665	174	672	189	678	208	681	225	683	241
	8	607	181	630	190	644	200	666	213	665	228	672	247	677	263	680	280
	10	590	220	617	229	634	238	648	251	659	266	668	285	692	302	676	318
	12	574	259	605	268	625	277	640	290	653	306	663	324	668	341	672	357
	14	559	298	593	306	615	316	633	329	648	344	658	363	665	380	669	396
	16	544	336	582	345	607	354	626	367	642	382	654	402	661	418	666	434
	18			571	384	598	393	620	406	637	421	650	440	657	457	663	473
	20					590	432	613	445	632	460	646	479	654	496	660	512
	22							607	484	627	499	642	518	651	534	657	551
FTSW10-128	2	775	76	785	86	792	97	797	111	801	129	804	151	806	170	808	188
	4	747	121	764	131	775	142	787	157	790	174	797	196	799	215	801	234
	6	722	166	745	176	760	187	769	202	781	219	789	241	793	260	797	279
	8	699	211	728	221	747	232	759	247	773	264	782	286	787	305	791	324
	10	677	257	711	267	733	278	749	292	765	310	776	331	782	351	787	369
	12	660	302	696	312	721	323	739	338	758	355	770	377	777	396	782	415
	14	637	347	680	357	710	368	730	383	751	400	764	422	772	441	778	460
	16					698	413	722	428	744	445	759	467	768	486	774	505
	18							713	473	737	491	753	512	763	532	770	550
FTSW10-150	2	995	98	1008	111	1017	125	1024	144	1029	166	1033	194	1035	219	1037	243
	4	959	156	981	169	995	183	1008	202	1015	224	1022	252	1026	277	1029	301
	6	927	214	956	227	976	241	992	260	1004	282	1013	310	1018	335	1022	359
	8	897	272	934	285	958	299	978	318	993	340	1004	369	1011	393	1016	417
	10	870	330	913	343	942	357	965	376	983	399	996	427	1004	451	1010	475
	12	843	388	894	401	926	415	953	434	973	457	989	485	998	510	1004	534
FTSW10-160	2	1062	105	1075	119	1084	134	1091	154	1096	177	1100	207	1102	234	1104	259
	4	1026	167	1048	182	1062	196	1074	216	1082	239	1089	269	1093	296	1096	322
	6	994	237	1023	245	1043	258	1059	278	1071	302	1080	331	1085	358	1089	384
	8	964	293	1001	306	1025	321	1045	341	1060	364	1071	395	1078	420	1083	446
	10	937	357	980	368	1009	384	1032	403	1050	428	1063	457	1071	483	1077	508
	12	910	420	961	433	993	446	1020	466	1040	490	1056	519	1065	546	1071	571

## FTSW Performance Parameters

The performance table of main technique

Speed n=1450r/min

Size	ΔP (bar)	Viscosity (mm <sup>2</sup> /s)															
		1		15		35		75		150		350		750		1500	
		m <sup>3</sup> /h	KW	m <sup>3</sup> /h	KW	m <sup>3</sup> /h	KW	m <sup>3</sup> /h	KW	m <sup>3</sup> /h	KW	m <sup>3</sup> /h	KW	m <sup>3</sup> /h	KW	m <sup>3</sup> /h	KW
FTSW11-176	0	1700		1750		1780		1800		1815		1820		1825		1830	
	2	1530	111	1645	127	1673	136	1728	148	1742	164	1747	179	1789	199	1793	215
	4	1445	210	1575	242	1602	260	1656	283	1670	314	1674	343	1716	381	1720	412
	6	1360	300	1550	350	1531	364	1584	388	1597	419	1602	452	1643	503	1647	525
	8	1275	375	1453	451	1477	468	1530	500	1543	540	1547	581	1583	647	1592	676
	10			1400	539	1424	554	1476	586	1488	620	1492	651	1533	730	1537	762
	12					1388	648	1440	686	1452	726	1456	763	1497	855	1501	893
	16					1353	842	1404	891	1416	944	1420	992	1460	1112	1464	1162
FTSW11-192	0	1850		1900		1952		2000		2020		2030		2035		2040	
	2	1665	121	1786	137	1835	149	1920	164	1939	182	1949	200	1994	222	1999	239
	4	1573	229	1710	263	1757	285	1840	315	1858	349	1868	383	1913	425	1918	459
	6	1480	326	1634	380	1679	399	1760	431	1778	466	1786	503	1832	561	1836	585
	8	1388	386	1577	490	1620	513	1700	556	1717	600	1726	649	1770	723	1775	754
	10			1520	573	1562	601	1640	651	1656	690	1665	727	1709	814	1714	850
	12					1523	703	1600	762	1616	808	1624	851	1669	954	1673	996
	16					1484	923	1560	990	1576	1051	1583	1106	1628	1240	1632	1295
FTSW11-224	0	2250		2300		2350		2400		2420		2430		2435		2440	
	2	2025	168	2160	177	2210	185	2300	197	2320	216	2330	238	2385	256	2390	276
	4	1910	321	2070	340	2115	359	2210	378	2230	415	2235	457	2290	491	2295	529
	6	1800	465	1980	491	2020	501	2110	517	2130	553	2140	595	2190	646	2195	672
	8	1685	600	1910	634	1950	647	2040	667	2060	714	2065	766	2120	834	2125	867
	10			1840	743	1880	758	1970	782	1985	821	1990	860	2070	938	2075	977
	12					1810	888	1920	915	1940	960	1945	1006	1995	1098	2000	1143
	16					1786	1165	1872	1189	1888	1248	1895	1308	1948	1427	1952	1486
FTSW11-250	0	2500		2550		2580		2600		2620		2630		2635		2640	
	2	2250	187	2400	192	2450	202	2496	213	2515	234	2545	256	2580	277	2585	298
	4	2125	359	2295	367	2345	388	2390	408	2410	449	2440	490	2475	530	2475	571
	6	2000	505	2190	533	2245	547	2290	561	2305	600	2337	645	2370	700	2375	729
	8	1875	650	2115	686	2167	704	2210	722	2225	773	2255	830	2290	903	2295	939
	10			2040	802	2090	823	2130	845	2150	887	2190	930	2240	1014	2245	1056
	12					2038	965	2080	990	2100	1040	2130	1090	2160	1188	2165	1238
	16					1960	1250	2020	1283	2040	1347	2070	1410	2105	1540	2110	1603

**FTSW Performance Parameters**

The performance table of main technique

Speed n=950r/min

Size	ΔP (bar)	Viscosity (mm <sup>2</sup> /s)															
		1		15		35		75		150		350		750		1500	
		m <sup>3</sup> /h	KW	m <sup>3</sup> /h	KW	m <sup>3</sup> /h	KW	m <sup>3</sup> /h	KW	m <sup>3</sup> /h	KW	m <sup>3</sup> /h	KW	m <sup>3</sup> /h	KW	m <sup>3</sup> /h	KW
FTSW2-12	2	2.4	0.2	2.4	0.2	2.5	0.2	2.7	0.2	2.7	0.3	2.8	0.3	2.9	0.3	3.2	0.3
	4	2.2	0.4	2.3	0.4	2.4	0.4	2.5	0.4	2.5	0.5	2.6	0.5	2.8	0.5	3	0.4
	6	2.2	0.5	2.3	0.6	2.4	0.6	2.5	0.6	2.5	0.7	2.6	0.7	2.8	0.8	3	0.9
	8	2.1	0.7	2.2	0.7	2.2	0.7	2.4	0.8	2.4	0.9	2.5	0.9	2.6	1	2.8	1.1
	10	2.1	0.8	2.2	0.9	2.2	0.9	2.4	0.9	2.4	1	2.5	1.2	2.6	1.2	2.8	1.3
	12	2	0.9	2	1	2.1	1	2.3	1.1	2.3	1.2	2.4	1.3	2.5	1.4	2.6	1.5
	14	1.9	1	1.9	1.1	2	1.1	2.2	1.2	2.2	1.4	2.3	1.4	2.5	1.6	2.5	1.7
	16	1.8	1.2	1.8	1.2	1.9	1.2	2.1	1.4	2.1	1.5	2.2	1.6	2.4	1.8	2.4	1.9
	18	1.7	1.2	1.7	1.3	1.9	1.3	2	1.4	2	1.6	2.1	1.7	2.3	1.9	2.3	2
	20	1.6	1.4	1.6	1.4	1.8	1.4	1.9	1.5	1.9	1.7	2	1.8	2.2	2	2.2	2.1
FTSW2-18	6	3.3	0.2	3.5	0.3	3.5	0.3	3.6	0.3	3.6	0.4	3.8	0.4	3.9	0.4	4.2	0.5
	8	3.2	0.5	3.2	0.5	3.4	0.5	3.5	0.6	3.5	0.7	3.6	0.7	3.8	0.8	4	0.9
	10	3.1	0.7	3.2	0.7	3.2	0.7	3.3	0.8	3.3	0.9	3.5	0.9	3.6	1.1	3.9	1.2
	12	3	0.9	3	0.9	3.1	0.9	3.2	1	3.2	1.2	3.3	1.2	3.5	1.3	3.8	1.4
	14	2.7	1	2.7	1.1	2.8	1.1	3.1	1.2	3.1	1.3	3.2	1.4	3.3	1.4	3.6	1.6
	16	2.4	1.2	2.5	1.3	2.5	1.3	2.9	1.4	2.9	1.6	3.1	1.7	3.2	1.8	3.5	1.9
	18	2.2	1.4	2.3	1.5	2.4	1.5	2.9	1.6	2.8	1.8	3	1.9	3.1	2.1	3.4	2.2
	20	2.1	1.6	2.1	1.7	2.3	1.7	2.8	1.8	2.8	2	2.9	2.1	3	2.3	3.3	2.5
	22	1.9	1.8	2	1.9	2.1	1.9	2.7	1.9	2.7	2.1	2.8	2.3	3	2.5	3.3	2.8
	24	1.8	2	1.9	2.1	2	2.1	2.6	2.1	2.6	2.3	2.8	2.5	2.9	2.8	3.2	3
FTSW2-24	2	3.9	0.2	4	0.3	4	0.3	4.3	0.4	4.3	0.5	4.6	0.5	5	0.5	5.32	0.5
	4	3.8	0.6	3.9	0.7	3.9	0.7	4.2	0.7	4.2	0.8	4.4	0.9	4.8	0.9	5.2	0.9
	6	3.6	0.9	3.7	0.9	3.8	0.9	4	1	4	1.1	4.3	1.2	4.6	1.3	5	1.4
	8	3.5	1.2	3.5	1.2	3.6	1.2	3.9	1.3	3.9	1.4	4.2	1.5	4.5	1.7	4.9	1.8
	10	3.3	1.4	3.4	1.4	3.5	1.4	3.8	1.5	3.8	1.6	4	1.7	4.3	2.1	4.8	2.1
	12	3.2	1.6	3.3	1.6	3.4	1.6	3.6	1.7	3.6	1.9	3.9	2	4.2	2.3	4.5	2.4
	14	3.1	1.8	3.1	1.8	3.2	1.8	3.5	1.9	3.5	2.1	3.8	2.2	4	2.5	4.3	2.7
	16	2.9	2	3	2	3.1	2	3.4	2.1	3.3	2.3	3.6	2.4	3.9	2.7	4.2	3
	18	2.8	2.2	2.9	2.2	2.9	2.2	3.2	2.3	3.2	2.5	3.5	2.6	3.8	2.9	4.1	3.2
	20	2.7	2.3	2.7	2.4	2.8	2.4	3.1	2.5	3.1	2.7	3.3	2.8	3.6	3.2	3.9	3.5
FTSW2-36	2	6.1	0.4	6.2	0.5	6.3	0.5	6.6	0.6	6.6	0.7	6.8	0.7	7.3	0.8	7.7	0.9
	4	5.9	0.8	6	0.9	6	0.9	6.3	1	6.3	1.1	6.6	1.2	6.9	1.3	7.3	1.4
	6	5.6	1.3	5.7	1.4	5.7	1.4	6	1.4	6	1.6	6.3	1.5	6.7	1.8	7.1	2
	8	5.3	1.6	5.4	1.7	5.4	1.7	5.7	1.8	5.7	2	6	2.1	6.5	2.3	6.8	2.5
	10	5	2	5.1	2.1	5.2	2.1	5.5	2.1	5.5	2.3	5.7	2.5	6.2	2.7	6.6	3
	12	4.9	2.4	5	2.5	5	2.5	5.3	2.5	5.3	2.8	5.6	3.1	6	3.2	6.4	3.5
	14	4.7	2.8	4.8	2.8	4.9	2.8	5.2	2.8	5.2	3.2	5.4	3.5	5.9	3.8	6.3	4.1
	16	4.6	3	4.7	3.1	4.7	3.1	5	3.2	5	3.5	5.3	3.9	5.74	4.2	6.1	4.5
	18	4.2	3.2	4.3	3.3	4.3	3.3	4.8	3.3	4.7	3.7	5.1	4	5.5	4.4	6	4.2
	20	3.8	3.4	3.8	3.5	3.9	3.5	4.5	3.5	4.5	3.9	4.9	4.2	5.3	4.5	5.9	4.9
FTSW2-48	2	8.9	0.6	9	0.7	9.1	0.7	9.4	0.8	9.4	0.9	9.8	0.9	10.2	1	10.8	1.1
	4	8.7	1.3	8.7	1.4	8.8	1.4	9.1	1.4	9.1	1.6	9.5	1.7	9.9	1.8	10.5	1.9
	6	8.4	2	8.4	2	8.5	2	8.8	2.1	8.8	2.3	9.1	2.5	9.5	2.7	10.1	2.9
	8	7.8	2.5	7.9	2.5	8	2.5	8.3	2.6	8.3	2.9	8.7	3.1	9.1	3.4	9.5	3.6
	10	7.6	3	7.6	3.1	7.7	3.1	8	3.2	8	3.5	8.4	3.9	8.8	4.2	9.2	4.6
	12	7.3	3.4	7.3	3.5	7.4	3.5	7.7	3.6	7.7	3.9	8.1	4.3	8.5	4.6	9.1	5
	14	6.9	4	7	3.9	7.1	3.9	7.4	4	7.4	4.4	7.8	4.8	8.3	5.3	8.9	5.7
	16	6.6	4.3	6.6	4.4	6.7	4.4	7.1	4.5	7.1	4.9	7.6	5.4	8	5.9	8.7	6.3
	18	6	4.6	6.1	4.6	6.2	4.6	6.7	4.7	6.7	5.2	7.1	5.7	7.6	6.1	8.2	6.6
	20	5	4.8	5.5	4.8	5.6	4.8	6.3	4.9	6.3	5.4	6.7	5.9	7.1	6.4	7.7	6.9

## FTSW Performance Parameters

The performance table of main technique

Speed n=950r/min

Size	ΔP (bar)	Viscosity (mm <sup>2</sup> /s)															
		1		15		35		75		150		350		750		1500	
		m <sup>3</sup> /h	KW	m <sup>3</sup> /h	KW	m <sup>3</sup> /h	KW	m <sup>3</sup> /h	KW	m <sup>3</sup> /h	KW	m <sup>3</sup> /h	KW	m <sup>3</sup> /h	KW	m <sup>3</sup> /h	KW
2W3-20	2	4.6	1	4.9	1.2	5.1	1.4	5.3	1.8	5.4	2.1	5.5	2.7	5.6	3.4	5.7	3.8
	4	3.8	1.3	4.3	1.6	4.6	1.8	4.9	2.1	5.1	2.5	5.3	3	5.4	3.7	5.5	4.2
	6	3	1.7	3.7	1.9	4.2	2.1	4.6	2.4	4.8	2.8	5.1	3.4	5.3	4.1	5.4	4.5
	8	2.5	2.2	3.2	2.2	3.8	2.5	4.2	2.8	4.6	3.2	4.9	3.7	5.1	4.4	5.3	4.8
	10	2.1	2.8	2.7	2.6	3.4	2.8	3.9	3.1	4.3	3.5	4.7	4.1	4.9	4.7	5.2	5.2
	12			2.4	3.1	3	3.2	3.7	3.5	4.1	3.8	4.5	4.4	4.8	5.1	5.1	5.5
	14			2.2	3.7	2.6	3.6	3.4	3.8	3.9	4.2	4.4	4.8	4.7	5.4	5	5.9
	16					2.3	4	3.2	4.2	3.8	4.5	4.3	5.1	4.6	5.8	4.9	6.2
	18							3	4.6	3.6	4.9	4.1	5.4	4.5	6.1	4.8	6.6
	20									3.4	5.2	1	5.8	4.4	6.5	4.7	6.9
	22											3.9	6.1	4.3	6.8	4.6	7.3
24											3.8	6.5	4.2	7.1	4.5	7.6	
2W3-28	2	6.3	1.2	6.7	1.4	7	1.6	7.2	2	7.4	2.4	7.5	3	7.6	3.7	7.7	4.2
	4	5.2	1.6	5.9	1.9	6.3	2.1	6.7	2.4	6.9	2.8	7.2	4.3	7.4	4.2	7.5	4.6
	6	4.2	2.1	5.1	2.3	5.7	2.6	6.2	2.9	6.6	3.3	6.9	3.9	7.1	4.6	7.3	5.1
	8	3.3	2.6	4.4	2.8	5.2	3	5.8	3.4	6.2	3.8	6.7	4.4	6.9	5.1	7.2	5.6
	10	2.6	3.2	3.8	3.3	4.6	3.5	5.4	3.8	5.9	4.2	6.4	4.8	6.8	5.6	7	6
	12			3.3	3.9	4.2	4	5	4.3	5.6	4.7	6.2	5.3	6.6	6	6.9	6.5
	14			2.9	4.6	3.7	4.4	4.6	4.8	5.3	5.2	6	5.8	6.4	6.5	6.7	7
	16					3.3	4.8	4.4	5.2	5.2	5.6	5.8	6.2	6.3	7	6.6	7.4
	18							4.2	5.6	4.9	6.1	5.6	6.7	6.2	7.4	6.5	7.9
	20									4.7	6.6	5.5	7.2	6	7.9	6.4	8.4
2W3-40	2	9.7	1.4	10.2	1.7	10.5	1.9	10.8	2.3	11	2.7	11.2	3.4	11.3	4.1	11.4	4.6
	4	8.3	2.1	9.1	2.4	9.7	2.6	10.1	3	10.5	3.4	10.8	4	11	4.8	11.2	5.3
	6	7	2.8	8.2	3	8.9	3.3	9.6	3.7	10	4.1	10.4	4.7	10.7	5.5	10.9	6
	8	5.9	3.5	7.3	3.7	8.2	4	9	4.4	9.6	4.8	10.1	5.4	10.5	6.2	10.7	6.7
	10			6.5	4.4	7.6	4.7	8.5	5	9.2	5.5	9.8	6.1	10.2	6.9	10.6	7.4
	12					7	5.4	8.1	5.7	8.8	6.1	9.5	6.8	10	7.6	10.4	8.1
	14							7.6	6.4	8.5	6.8	9.3	7.5	9.8	8.2	10.2	8.8
16									8.2	7.5	9.1	8.2	9.7	8.9	10.1	9.5	
2W3-56	2	13.6	1.8	14.3	2	14.8	2.3	15.1	2.7	15.4	3.2	15.7	3.9	15.9	4.8	16	5.3
	4	11.7	2.8	12.8	3	13.6	3.3	14.2	3.7	14.7	4.2	15.1	4.9	15.4	5.7	15.6	6.3
	6			11.6	4	12.6	4.3	13.4	4.7	14.1	5.1	14.7	5.8	15.1	6.7	15.3	7.3
	8							12.7	5.6	13.5	6.1	14.2	6.8	14.7	7.7	15.1	8.2
	10									12.9	7.1	13.8	7.8	14.4	8.6	14.8	9.2
2W4-25	2	9.4	1.5	10	1.8	10.3	2.1	10.6	2.5	10.9	3	11	3.7	11.2	4.6	11.3	5.2
	4	7.9	2.2	8.8	2.5	9.4	2.8	9.9	3.2	10.2	3.7	10.6	4.4	10.8	5.3	11	5.9
	6	6.6	2.9	7.8	3.2	8.6	3.5	9.3	3.9	9.8	4.4	10.2	5.1	10.5	6	10.8	6.6
	8	5.3	3.6	6.9	3.9	7.9	4.2	8.7	4.6	9.3	5	9.9	5.8	10.3	6.7	10.6	7.2
	10	4.2	4.5	6	4.5	7.2	4.8	8.2	5.2	8.9	5.7	9.6	6.5	10	7.3	10.4	7.9
	12	3.3	5.6	5.2	5.2	6.5	5.5	7.7	5.9	8.5	6.4	9.3	7.1	9.8	8	10.2	8.6
	14			4.5	6	5.9	6.2	7.2	6.6	8.1	7.1	9	7.8	9.6	8.7	10	9.3
	16					5.3	7	6.9	7.3	7.9	7.8	8.8	8.5	9.4	9.4	9.9	10
	18					4.8	7.9	6.5	8	7.6	8.4	8.5	9.2	9.2	10.1	9.7	10.7
	20							6.1	8.6	7.2	9.1	8.3	9.9	9	10.7	9.6	11.3
	22									6.9	9.8	8.1	10.5	8.9	11.4	9.4	12
	24									6.6	10.5	7.8	11.2	8.7	12.1	9.3	12.7

**FTSW Performance Parameters**

The performance table of main technique

Speed n=950r/min

Size	ΔP (bar)	Viscosity (mm <sup>2</sup> /s)															
		1		15		35		75		150		350		750		1500	
		m <sup>3</sup> /h	KW	m <sup>3</sup> /h	KW	m <sup>3</sup> /h	KW	m <sup>3</sup> /h	KW	m <sup>3</sup> /h	KW	m <sup>3</sup> /h	KW	m <sup>3</sup> /h	KW	m <sup>3</sup> /h	KW
2W4-34	2	13.3	1.9	13.9	2.2	14.3	2.5	14.7	2.9	15	3.5	15.1	4.3	15.3	5.3	15.4	5.9
	4	11.5	2.8	12.5	3.1	13.2	3.4	13.8	3.9	14.2	4.4	14.6	5.2	14.9	6.2	15.1	6.8
	6	9.9	3.7	11.4	4	12.3	4.4	13.1	4.8	13.7	5.3	14.2	6.1	14.6	7.1	14.8	7.8
	8	8.5	4.7	10.3	5	11.5	5.3	12.4	5.7	13.1	6.3	13.8	7	14.3	8	14.6	8.7
	10	7.3	5.9	9.3	5.9	10.6	6.2	11.8	6.7	12.6	7.2	13.4	8	14	9	14.4	9.6
	12			8.3	6.8	9.9	7.1	11.2	7.6	12.2	8.1	13.1	8.9	13.7	9.9	14.1	10.5
	14			7.4	7.8	9.1	8.1	10.6	8.5	11.7	9	12.7	9.9	13.4	10.8	13.9	11.5
	16					8.7	9	10.3	9.4	11.5	10	12.5	10.8	13.3	11.8	13.8	12.4
	18							9.8	10.4	11.1	10.9	12.3	11.7	13.1	12.7	13.6	13.3
	20						9.4	11.3	10.7	11.8	12	12.6	12.8	13.6	13.5	14.3	
2W4-50	2	19.9	2.5	20.7	2.8	21.3	3.2	21.7	3.7	22.1	4.3	22.4	5.3	22.6	6.4	22.7	7.2
	4	17.5	3.8	19	4.2	19.9	4.6	20.6	5.1	21.2	5.7	21.7	6.6	22.1	7.8	22.3	8.5
	6	15.5	5.2	17.4	5.5	18.6	5.9	19.7	6.4	20.4	7.1	21.1	8	21.6	9.1	22	9.9
	8	13.6	6.6	16	6.9	17.5	7.3	18.8	7.8	19.7	8.4	20.6	9.4	21.2	10.5	21.7	11.3
	10	11.8	7.9	14.6	8.3	16.5	8.6	18	9.2	19.1	9.8	20.1	10.7	20.8	11.9	21.4	12.6
	12			13.4	9.6	15.4	10	17.1	10.5	18.5	11.2	19.6	12.1	20.5	13.2	21.1	14
	14					14.5	11.4	16.4	11.9	17.9	12.5	19.2	13.5	20.1	14.6	20.8	15.3
	16						16	13.3	17.5	13.9	18.9	14.8	19.9	16	20.6	16.7	
2W4-72	2	28.5	3.2	29.7	3.7	30.5	4.1	31.2	4.7	31.7	5.4	32.1	6.5	32.4	7.9	32.7	8.7
	4	25	5.2	27.1	5.6	28.4	6.1	29.6	6.7	30.4	7.4	31.2	8.5	31.7	9.8	32.1	10.7
	6			24.8	7.6	26.6	8	28.2	8.6	29.3	9.4	30.3	10.5	31	11.8	31.6	12.7
	8					25	10	26.9	10.6	28.2	11.3	29.5	12.4	30.4	13.8	31.1	14.6
	10							25.7	12.6	27.3	13.8	28.8	14.4	29.9	15.7	30.6	16.6
2W5-30	2	17.4	3	18.1	3.6	18.5	4.2	18.9	5.1	19.1	6.1	19.4	7.7	19.5	9.6	19.7	10.8
	4	15.5	4.2	16.7	4.8	17.4	5.4	18	6.3	18.4	7.3	18.8	8.9	19.1	10.8	19.3	12
	6	13.9	5.4	15.4	5.9	16.4	6.6	17.2	7.5	17.8	8.5	18.4	10.1	18.8	11.9	19.1	13.2
	8	12.4	6.5	14.3	7.1	15.5	7.8	16.5	8.6	17.3	9.6	18	11.2	18.5	13.1	18.8	14.4
	10	11	7.7	13.2	8.3	14.7	8.9	15.9	9.8	16.8	10.8	17.6	12.4	18.1	14.3	18.6	15.5
	12	9.7	9.1	12.2	9.5	13.9	10.1	15.3	11	16.3	12	17.2	13.6	17.9	15.5	18.3	16.7
	14			11.2	10.7	13.1	11.3	14.7	12.2	15.8	13.2	16.8	14.8	17.6	16.6	18.1	17.9
	16			10.3	12.1	12.7	12.5	14.3	13.3	15.5	14.4	16.6	15.9	17.4	17.8	18	19.1
	18					12	13.6	13.8	14.5	15.1	15.5	16.3	17.1	17.2	19	17.8	20.2
	20					11.4	14.8	13.3	15.7	14.7	16.7	16	18.3	17	20.2	17.6	21.4
	22							12.8	16.9	14.3	17.9	15.7	19.5	16.7	21.4	17.4	22.6
	24							12.4	18	14	19.1	15.5	20.6	16.5	22.5	17.3	23.8
2W5-40	2	23.5	3.5	24.4	4.1	24.9	4.8	25.3	5.7	25.6	6.8	25.9	8.5	26.1	10.5	26.3	11.8
	4	21.3	5.1	22.6	5.7	23.5	6.4	24.3	7.3	24.8	8.4	25.3	10.1	25.7	12.1	25.9	13.4
	6	19.3	6.6	21.1	7.3	22.3	8	23.3	8.9	24.1	10	24.8	11.6	25.2	13.6	25.6	15
	8	17.5	8.2	19.8	8.8	21.2	9.5	22.5	10.5	23.4	11.5	24.2	13.2	24.8	15.2	25.2	16.5
	10	15.7	9.8	18.5	10.4	20.2	11.1	21.7	12	22.8	13.1	23.8	14.8	24.5	16.8	25	18.1
	12			17.2	12	19.2	12.7	20.9	13.6	22.2	14.7	23.3	16.4	24.1	18.4	24.7	19.7
	14			16	13.6	18.3	14.2	20.2	15.2	21.6	16.2	22.9	17.9	23.8	19.9	24.4	21.3
	16					17.8	15.8	19.8	16.7	21.3	17.8	22.6	19.5	23.6	21.5	24.3	22.8
	18							19.2	18.3	20.8	19.4	22.3	21.1	23.3	23.1	24	24.4
20							18.6	19.9	20.3	21	21.9	22.6	23	24.6	23.8	26	

## FTSW Performance Parameters

The performance table of main technique

Speed n=950r/min

Size	ΔP (bar)	Viscosity (mm <sup>2</sup> /s)															
		1		15		35		75		150		350		750		1500	
		m <sup>3</sup> /h	KW	m <sup>3</sup> /h	KW	m <sup>3</sup> /h	KW	m <sup>3</sup> /h	KW	m <sup>3</sup> /h	KW	m <sup>3</sup> /h	KW	m <sup>3</sup> /h	KW	m <sup>3</sup> /h	KW
FTSW5-60	2	35.7	4.5	36.8	5.3	37.6	6	38.2	7.1	38.6	8.3	39	10.2	39.3	12.5	39.5	14
	4	32.7	6.9	34.5	7.6	35.7	8.4	36.7	9.4	37.4	10.6	38.1	12.6	38.6	14.8	38.9	16.3
	6	30	9.3	32.5	10	34.1	10.7	35.5	11.8	36.5	13	37.4	14.9	38	17.2	38.5	18.7
	8			30.6	12.3	32.6	13.1	34.3	14.1	35.5	15.4	36.7	17.3	37.5	19.5	38.1	21
	10			28.8	14.7	31.2	15.4	33.2	16.8	34.7	17.7	36	19.6	37	21.9	37.7	23.4
	12					29.9	17.8	32.2	18.8	33.9	20.1	35.4	22	36.5	24.2	37.3	25.7
	14					28.6	20.1	31.2	21.2	33.1	22.4	34.8	24.3	36	26.6	36.9	28.1
	16							30.7	23.5	32.6	24.8	34.5	26.7	35.8	28.9	36.7	30.4
FTSW5-80	2	46.3	5.6	48.1	6.4	49.3	7.2	50.3	8.4	51	9.8	51.7	11.9	52.1	14.4	52.5	16.1
	4	41.2	8.7	44.3	9.5	46.3	10.4	47.9	11.6	49.1	12.9	50.2	15	51	17.6	51.6	19.3
	6			40.9	12.7	43.6	13.5	45.9	14.7	47.5	16.1	49	18.2	50.1	20.7	50.8	22.4
	8					41.2	16.7	44	17.8	46	19.2	47.9	21.3	49.2	23.9	50.1	25.5
	10							42.2	21	44.6	22.3	46.8	24.5	48.4	27	49.5	28.7
FTSW6-38	2	33.9	4	34.8	4.6	35.4	5.2	35.9	6.1	36.3	7.1	36.6	8.7	36.8	10.6	37	11.9
	4	31.3	6.2	32.8	6.8	33.8	7.5	34	8.3	35.3	9.3	35.7	10.9	36.3	12.8	36.6	14.1
	6	29	8.4	31.1	9	32.5	9.6	33.6	10.5	34.5	11.5	35.2	13.1	35.8	15	36.2	16.3
	8	26.9	10.6	29.5	11.2	31.2	11.9	32.7	12.7	33.7	13.7	34.7	15.3	35.3	17.2	35.8	18.5
	10	24.9	12.8	28	13.4	30.1	14.1	31.7	14.9	33	15.9	34.1	17.5	34.9	19.4	35.5	20.7
	12	23.1	15	26.6	15.6	28.9	16.3	30.9	17.1	32.3	18.2	33.6	19.7	34.5	21.6	35.1	22.9
	14	21.3	17.2	25.3	17.8	27.9	18.5	30	19.3	31.6	20.4	33.1	21.9	34.1	23.8	34.8	25.1
	16			24.5	20	27.3	20.7	29.6	21.5	31.3	22.6	32.8	24.1	33.9	26	34.7	27.7
	18					26.4	22.9	28.9	23.7	30.7	24.8	32.4	26.3	33.6	28.2	34.4	29.5
	20							28.2	25.9	30.1	27	32	28.5	33.2	30.4	34.1	31.7
	22							27.5	28.1	29.6	29.2	31.6	30.7	32.9	32.6	33.9	33.9
	24									29.1	31.4	31.2	32.7	32.6	34.8	33.7	36.1
FTSW6-50	2	45.3	4.9	46.3	5.6	47	6.3	47.6	7.3	48	8.5	48.3	10.2	48.6	12.4	48.8	13.8
	4	42.3	7.8	44.1	8.5	45.2	9.2	46.2	10.2	46.9	11.4	47.5	13.1	48	15.2	48.3	16.7
	6	39.8	10.7	42.2	11.4	43.7	12.1	45	13.1	45.9	14.2	46.8	16	47.4	18.1	47.9	19.6
	8	37.4	13.6	40.4	14.3	42.3	15	43.9	16	45.1	17.1	46.2	18.9	46.9	21	47.5	22.4
	10			38.7	17.2	41	17.9	42.9	18.9	44.3	20	45.5	21.8	46.4	23.9	47.1	25.3
	12			37.1	20.1	39.7	20.8	41.9	21.8	43.5	22.9	45	24.7	46	26.8	46.7	28.2
	14					38.5	23.7	41	24.7	42.7	25.8	44.4	27.6	45.6	29.7	46.4	31.1
	16							40.5	27.6	42.3	28.7	44.1	30.5	45.3	32.6	46.2	34
	18							39.7	30.5	41.7	31.6	43.6	33.4	44.9	35.5	45.9	36.9
	20									41.1	34.5	43.2	36.3	44.6	38.4	45.6	39.8
	FTSW6-75	2	67.6	6.8	69.3	7.6	70.3	8.4	71.2	9.6	71.9	11	72.5	13.1	72.9	15.6	73.2
4		63.1	11.1	65.9	11.9	67.6	12.8	69.1	14	70.2	15.3	71.2	17.5	71.9	20	72.4	21.7
6		59.1	15.5	62.8	16.3	65.2	17.1	67.3	18.3	68.7	19.7	70.1	21.8	71	24.3	71.7	26
8				60.1	20.6	63.1	21.5	65.6	22.7	67.4	24	68.2	26.1	70.2	28.7	71.1	30.4
10				57.5	25	61	25.8	64	27	66.1	28.4	67.1	30.5	69.5	33	70.5	34.7
12						59.1	30.2	62.5	31.3	64.9	32.7	66	34.8	68.8	37.4	69.9	39
14								61	35.7	63.7	37.1	65.8	39.2	68.1	41.7	69.4	43.4
16										63.1	41.4	63.7	43.5	67.7	46.1	69.1	47.7
FTSW6-96	2	84.6	8.3	87.2	9.2	88.9	10.1	90.2	11.4	91.2	13	92.2	15.3	92.8	18.2	93.3	20
	4	77.5	13.9	81.8	14.7	84.6	15.7	86.9	17	88.6	18.6	92.2	20.9	91.3	23.7	92.1	25.6
	6					80.9	21.3	84	22.6	86.3	24.1	88.4	26.5	89.9	29.3	91	31.2
	8									84.2	29.7	86.8	32	88.7	34.6	90	36.7
	10									82.2	35.2	85.3	37.6	87.5	40.4	89.1	42.3

**FTSW Performance Parameters**

The performance table of main technique

Speed n=950r/min

Size	ΔP (bar)	Viscosity (mm2/s)															
		1		15		35		75		150		350		750		1500	
		m3/h	KW	m3/h	KW	m3/h	KW	m3/h	KW	m3/h	KW	m3/h	KW	m3/h	KW	m3/h	KW
FTSW7-43	2	54	6.8	55.4	7.9	56.4	9	57.2	10.6	57.7	12.5	58.3	15.3	58.6	18.7	58.9	21
	4	50	10.3	52.4	11.4	53.9	12.5	55.3	14.1	56.3	16	57.1	18.8	57.8	22.2	58.2	24.5
	6	46.4	13.8	49.7	14.9	51.8	16	53.6	17.6	54.9	19.5	56.2	22.3	57	25.7	57.6	28
	8	43.1	17.3	47.2	18.4	49.9	19.5	52.1	21.1	53.7	23	55.2	25.8	56.3	29.3	57	31.5
	10	40.1	20.8	44.9	21.9	48.1	23.1	50.7	24.6	52.6	26.5	54.4	29.3	55.6	32.8	56.5	35
	12	37.1	24.3	42.7	25.4	46.3	26.6	49.3	28.1	51.5	30	53.6	32.9	55	36.3	56	38.5
	14	34.3	27.8	40.6	28.9	44.7	30.1	48.1	31.6	50.5	33.5	52.8	36.4	54.4	39.8	55.5	42
	16			39.4	32.4	43.7	33.6	47.3	35.1	49.9	37	52.4	39.9	54	43.4	55.3	45.5
	18			37.6	35.9	42.3	37.1	46.2	38.7	49	40.5	51.7	43.4	53.5	46.8	54.9	49
	20			35.9	39.4	40.9	40.6	45.1	42.2	48.2	44	51	46.9	53	50.3	54.5	52.5
	22					39.6	44.1	44.1	45.7	47.4	47.5	50.4	50.4	52.5	53.8	54.1	56.1
	24							43.1	49.2	46.5	51	49.8	53.9	52.1	57.3	53.7	59.6
FTSW7-56	2	70.3	8.2	72.2	9.4	73.4	10.7	74.5	12.4	75.2	14.4	75.9	17.6	76.4	21.4	76.7	23.9
	4	65.1	12.8	68.2	13.9	70.3	15.2	72	17	73.3	19.7	74.4	22.2	75.2	25.9	75.8	28.4
	6	60.4	17.3	64.7	18.5	67.5	19.8	69.9	21.5	71.6	23.6	73.1	26.7	74.2	30.5	75	33
	8	56.2	21.9	61.5	23.1	65	24.4	67.9	26.1	70	28.1	71.9	31.3	73.3	35.1	74.3	37.6
	10	52.2	26.5	58.5	27.6	62.6	28.9	66	30.7	68.5	32.7	74.8	35.9	72.4	39.6	73.6	42.1
	12			55.7	32.2	60.4	33.5	64.3	32.2	67.1	37.3	69.8	40.4	71.6	44.1	73	46.7
	14					58.2	38	62.6	39.8	65.8	41.8	68.8	45	70.8	48.8	72.3	51.3
	16							61.7	44.4	65	46.4	68.2	49.6	70.4	53.3	72	55.8
	18									63.9	51	67.3	54.1	69.7	57.9	71.4	60.4
	20									62.8	55.5	66.5	58.7	69	62.5	70.9	64.9
FTSW7-85	2	106.6	11.2	109.5	12.6	111.4	14.1	113	16.1	114.1	18.5	115.2	22.2	115.9	26.6	116.5	29.6
	4	98.5	18.1	103.3	19.5	106	21	109.2	23	111.1	25.4	112.9	29.1	114.2	33.6	115.1	36.5
	6	91.4	25.1	98	26.4	104.6	27.9	105.9	30	108.5	32.4	110.9	36.1	112.6	40.5	113.8	43.4
	8			93.1	33.4	102.3	34.9	102.9	36.9	106.1	39.3	109.1	43	111.2	47.4	112.7	50.3
	10					98.4	41.8	100	43.8	103.8	46.2	107.4	49.9	109.9	54.3	111.7	57.3
	12					94.8	45.2	97.3	50.8	101.7	53.2	105.8	56.9	108.6	61.3	110.7	64.2
	14							99.6	60.1	104.2	63.8	107.4	68.2	109.7	71.1		
	16									98.5	67	103.4	70.7	106.7	75.1	109.2	78.1
FTSW7-112	2	141.2	14.1	144.9	15.7	147.2	17.4	149.2	19.8	150.6	22.6	152	26.9	152.9	32	153.5	35.4
	4	131.1	23.2	137.2	24.8	141.2	26.5	144.5	28.9	146.9	31.7	149.1	36	150.7	41.1	151.8	44.5
	6			130.5	33.9	135.9	35.7	140.4	38	143.6	40.8	146.6	45.1	148.8	50.2	150.3	53.6
	8							136.6	47.2	140.6	49.9	144.4	54.2	147	59.4	148.9	62.8
	10									137.8	59.1	142.2	63.4	145.3	68.5	147.5	71.9
FTSW8-50	2	98.4	13.1	100.2	15.4	101.4	17.8	102.4	21.1	103.1	25	103.7	31.1	104.2	38.2	104.5	43
	4	93.3	19.3	96.4	21.6	98.3	24	100	27.3	101.2	31.2	102.3	37.2	103.1	44.4	103.7	49.2
	6	88.9	25.5	93	27.8	95.7	30.2	97.9	33.5	99.6	37.4	101.1	43.4	102.1	50.6	102.9	55.4
	8	84.8	31.7	89.9	33.9	93.3	36.4	96	39.7	98.1	43.6	99.9	49.6	101.3	56.8	102.2	61.6
	10	81	37.9	87	40.1	90.9	42.6	94.3	45.9	96.6	49.8	98.9	55.8	100.4	63	101.5	67.7
	12	77.3	44.1	87.3	46.3	88.8	48.8	92.6	52.1	95.3	56	97.9	62	99.6	69.2	100.9	73.9
	14	73.8	50.3	81.6	52.5	86.7	54.9	91	58.3	94	62.1	96.9	68.2	98.9	75.4	100.3	80.1
	16	71.9	56.4	80.2	58.7	85.6	61.1	90	64.4	93.3	68.3	96.3	74.4	98.5	81.5	100	86.3
	18	68.9	62.6	77.9	64.5	83.8	67.3	88.7	70.6	92.2	74.5	95.5	80.1	97.8	87.8	99.5	92.5
	20			75.7	71.1	82	73.5	87.3	76.8	91.1	80.7	94.7	86.7	97.2	93.9	99	98.7
	22					80.3	79.7	86	83	90.1	86.9	93.9	92.9	96.6	100.1	98.5	104.9
	24							84.7	89.2	89.1	93.1	93.1	99.1	96	106.3	98	111.1

## FTSW Performance Parameters

The performance table of main technique

Speed n=950r/min

Size	ΔP (bar)	Viscosity (mm <sup>2</sup> /s)															
		1		15		35		75		150		350		750		1500	
		m <sup>3</sup> /h	KW	m <sup>3</sup> /h	KW	m <sup>3</sup> /h	KW	m <sup>3</sup> /h	KW	m <sup>3</sup> /h	KW	m <sup>3</sup> /h	KW	m <sup>3</sup> /h	KW	m <sup>3</sup> /h	KW
FTSW8-67	2	132	16	135	18	136	21	137	24	138	28	139	34	139	42	140	47
	4	125	24	130	26	132	29	134	32	135	36	137	43	138	50	139	55
	6	120	32	125	35	128	37	131	41	133	45	135	51	137	59	138	64
	8	114	40	121	43	125	45	129	49	131	53	134	59	135	67	137	73
	10	109	49	118	51	122	54	126	57	130	61	132	68	134	75	136	80
	12	105	57	114	59	119	62	124	65	128	70	131	76	133	83	135	88
	14	100	65	111	68	117	70	122	74	126	78	130	84	132	92	134	97
	16			109	76	115	79	121	82	125	86	129	92	132	100	134	105
	18			106	84	113	89	119	90	124	94	128	101	131	108	133	113
					111	95	118	99	122	103	127	109	130	117	133	122	
FTSW8-100	2	194	20	198	23	201	25	203	29	205	34	206	40	207	48	208	54
	4	182	33	189	35	194	38	197	42	200	46	203	53	205	61	206	66
	6	171	45	181	47	187	50	193	59	196	58	200	65	203	73	204	79
	8	162	57	174	60	181	63	188	66	193	71	197	77	200	86	203	91
	10	153	70	167	72	176	75	184	79	189	83	195	90	198	98	201	103
	12			160	85	171	87	180	91	186	95	192	102	197	110	200	116
	14					166	100	176	103	183	108	190	115	195	127	198	128
							174	116	182	120	189	127	189	135	197	134	
FTSW8-128	2	242	24	249	27	254	30	257	34	260	39	262	46	262	55	265	61
	4	223	40	235	43	242	46	248	50	253	55	257	62	257	74	262	77
	6	207	56	222	59	232	62	241	66	247	71	252	78	252	87	259	93
	8	191	72	211	75	223	78	234	82	241	87	248	94	248	103	257	109
	10			200	91	214	74	227	98	236	102	244	110	244	119	254	124
FTSW9-80	2	244	20	245	20	246	22	246	22	247	25	248	30	248	35	248	42
	4	232	35	233	35	235	38	235	38	236	45	237	54	237	63	238	75
	6	222	47	225	47	226	50	226	50	228	67	230	74	230	90	231	102
	8	212	57	215	57	218	60	218	60	221	85	223	98	223	113	225	127
	10	200	70	205	71	210	75	210	75	213	103	215	120	215	136	217	153
	12	185	80	193	82	200	86	200	86	205	118	208	137	208	156	220	177
	14			185	100	192	105	192	105	200	133	203	153	203	176	205	197
	16			176	110	184	117	184	117	189	147	192	170	192	193	195	217
	18					170	128	170	128	179	157	172	180	172	205	175	230
	20					153	135	162	135	165	160	168	182	168	208	172	233
	22							148	140	150	164	154	184	154	210	160	237
24							123	145	127	168	130	186	130	213	140	240	
FTSW9-100	2	310	25	312	25	313	27	313	27	314	32	316	37	316	43	320	52
	4	292	42	294	42	295	45	295	45	297	58	300	68	300	77	302	90
	6	282	57	284	57	285	60	285	60	287	83	290	96	290	110	292	125
	8	270	72	273	73	275	77	275	77	277	106	280	124	280	141	283	160
	10	258	86	262	87	265	82	265	82	268	130	270	150	270	170	273	190
	12	248	100	252	102	255	107	255	107	258	150	260	173	260	197	263	220
	14			235	124	238	130	238	130	246	167	250	193	250	220	253	247
	16			218	136	223	145	223	145	233	187	235	213	235	242	238	270
	18					216	162	215	162	227	200	230	228	230	260	233	293
	20					197	167	208	167	210	220	212	233	212	266	215	300
FTSW9-128	2	393	30	396	31	398	33	398	33	400	40	402	47	402	55	405	66
	4	376	52	380	53	382	55	382	55	385	75	387	87	387	100	390	110
	6	363	72	366	73	370	75	370	75	375	107	377	125	377	141	380	160
	8	350	92	354	94	358	97	358	97	362	138	365	160	365	183	368	207
	10	333	110	338	112	343	115	343	115	355	167	358	193	358	220	360	247
	12	320	128	324	130	330	135	330	135	333	193	336	224	336	256	340	287
	14			300	160	310	166	310	166	313	213	316	246	316	280	320	317
	16					280	193	280	193	285	233	290	270	290	306	295	347

**FTSW Performance Parameters**

The performance table of main technique

Speed n=950r/min

Size	ΔP (bar)	Viscosity (mm <sup>2</sup> /s)															
		1		15		35		75		150		350		750		1500	
		m <sup>3</sup> /h	KW	m <sup>3</sup> /h	KW	m <sup>3</sup> /h	KW	m <sup>3</sup> /h	KW	m <sup>3</sup> /h	KW	m <sup>3</sup> /h	KW	m <sup>3</sup> /h	KW	m <sup>3</sup> /h	KW
FTSW9-150	2	473	37	476	38	478	40	478	40	483	48	484	57	484	68	488	80
	4	443	62	448	64	450	66	450	66	455	88	456	103	456	118	460	135
	6	406	85	414	88	418	90	418	90	425	124	427	145	427	165	430	187
	8	380	107	388	110	392	113	392	113	395	160	402	186	402	213	405	240
	10	333	128	346	130	350	135	350	135	360	193	370	224	370	253	375	290
FTSW9-160	2	507	40	510	42	512	44	513	45	515	54	517	62	519	70	521	78
	4	477	76	481	80	484	84	486	86	487	102	490	118	493	134	497	149
	6	440	105	448	111	453	118	457	121	458	144	460	167	463	188	467	210
	8	413	131	421	140	428	149	427	150	429	180	431	208	435	236	440	264
	10	367	146	380	158	390	169	397	175	400	210	403	244	408	276	413	310
FTSW10-80	2	367	49	369	54	371	59	372	65	373	73	374	81	374	87	375	97
	4	359	70	362	75	365	80	367	86	369	95	370	102	371	108	372	118
	6	352	91	356	96	359	102	362	108	365	116	367	123	368	129	369	139
	8	345	112	350	117	355	123	358	129	361	137	364	145	365	150	367	160
	10	339	133	345	138	350	144	354	150	358	158	361	166	362	172	365	181
	12	333	154	340	159	346	165	350	171	355	179	358	187	360	193	362	203
	14	327	175	335	180	341	186	347	192	352	200	355	208	357	214	360	224
	16	322	197	330	201	337	207	343	213	349	221	353	229	355	235	358	245
	18	316	218	326	222	334	228	340	234	346	242	350	250	353	256	356	266
	20			321	244	330	249	336	255	343	263	348	271	351	277	354	287
	22					326	270	333	276	340	285	345	292	348	298	352	308
24					323	292	330	298	338	306	343	313	346	319	351	329	
FTSW10-100	2	441	58	443	64	445	70	447	77	448	87	449	96	450	103	451	115
	4	431	83	434	89	438	96	440	103	443	112	444	121	445	128	447	140
	6	442	109	427	114	431	121	434	128	438	138	440	147	442	154	443	165
	8	413	134	419	140	425	146	429	153	433	163	436	172	438	179	440	191
	10	405	159	413	165	419	172	427	179	429	188	433	198	435	204	437	216
	12	398	185	406	190	414	197	419	204	425	214	429	223	432	230	435	241
	14	391	210	400	216	409	223	415	230	421	239	426	248	429	255	432	297
	16	384	236	394	241	404	248	411	255	418	264	426	274	426	281	430	292
	18			389	267	399	273	406	280	414	290	420	299	423	306	427	318
	20			383	292	394	299	402	306	411	315	417	324				
	22					389	324	398	331	407	341						
24					385	349	394	356									
FTSW10-128	2	513	67	516	74	519	81	521	89	523	100	524	111	525	119	526	132
	4	500	97	505	103	509	111	521	119	515	130	518	141	519	148	521	162
	6	489	126	495	133	501	141	505	149	509	160	512	170	514	178	517	191
	8	478	156	486	162	493	170	495	178	504	189	507	200	510	208	513	221
	10	468	186	478	192	486	200	492	208	495	219	503	229	505	237	509	251
	12	459	215	469	222	479	229	486	238	493	248	498	259	501	267	506	280
	14	450	245	462	251	472	259	480	267	488	278	494	289	495	297	502	310
	16			454	281	466	289	475	297	484	308	490	318	494	326	499	340
	18			447	311	460	318	470	326	479	337						
	20					454	348	464	356	471	371						
	22					445	380	448	390	453	405						
24					420	420	425	435									
FTSW10-150	2	660	87	664	95	667	105	669	115	672	129	673	143	674	153	676	170
	4	643	125	649	133	654	143	658	153	663	168	665	181	667	191	669	209
	6	628	163	636	171	644	181	649	191	655	206	659	219	661	229	664	247
	8	615	201	625	209	634	219	641	230	647	244	652	257	655	267	659	285
	10	602	239	614	247	624	257	632	268	641	282	646	295	650	306	654	323
	12	590	277	603	285	616	295	625	306	634	320	641	333	645	344	650	361
	14			593	323	607	333	617	344	628	358						
FTSW10-160	2	708	70	717	79	723	89	727	103	731	118	733	138	735	156	736	173
	4	684	111	699	121	708	131	716	144	721	160	726	180	729	197	731	214
	6	663	158	682	163	695	172	706	186	714	201	720	221	723	239	726	256
	8	643	195	667	204	683	214	697	227	707	243	714	263	719	280	722	297
	10	625	238	653	245	673	256	688	269	700	285	709	305	714	322	718	339
	12	607	280	641	289	662	298	680	311	693	327	704	346	710	364	714	381

## FTSW Performance Parameters

The performance table of main technique

Speed n=950r/min

Size	ΔP (bar)	Viscosity (mm <sup>2</sup> /s)															
		1		15		35		75		150		350		750		1500	
		m <sup>3</sup> /h	KW	m <sup>3</sup> /h	KW	m <sup>3</sup> /h	KW	m <sup>3</sup> /h	KW	m <sup>3</sup> /h	KW	m <sup>3</sup> /h	KW	m <sup>3</sup> /h	KW	m <sup>3</sup> /h	KW
FTSW11-176	0	1133		1167		1187		1200		1210		1213		1217		1220	
	2	1020	74	1097	85	1115	91	1152	99	1161	109	1165	119	1193	133	1195	143
	4	963	140	1050	161	1068	173	1104	129	1113	209	1116	229	1144	254	1147	275
	6	906	200	1003	233	1021	243	1056	259	1065	279	1068	301	1095	335	1098	350
	8	850	250	969	301	985	312	1020	333	1029	360	1031	387	1055	431	1061	451
	10			933	359	949	369	984	391	992	413	995	434	1022	487	1025	508
	12					925	432	960	457	968	484	971	509	998	570	1001	595
	16					902	561	936	594	944	629	947	661	973	741	976	775
FTSW11-192	0	1233		1267		1301		1333		1347		1353		1357		1360	
	2	1110	81	1191	91	1223	99	1280	109	1293	121	1299	133	1329	148	1333	159
	4	1049	153	1140	175	1171	190	1227	210	1239	233	1245	255	1275	283	1279	306
	6	987	217	1089	253	1119	266	1173	287	1185	311	1191	335	1221	374	1224	390
	8	925	257	1051	327	1080	342	1133	370	1145	400	1151	433	1180	482	1183	503
	10			1013	382	1041	401	1093	434	1104	460	1110	485	1139	543	1143	567
	12					1015	469	1067	508	1077	539	1083	567	1113	636	1115	664
	16					989	615	1040	660	1051	701	1055	737	1085	827	1088	863
FTSW11-224	0	1500		1533		1567		1600		1613		1620		1623		1627	
	2	1350	112	1440	118	1473	123	1533	131	1547	144	1553	159	1590	171	1593	184
	4	1273	214	1380	227	1410	239	1473	252	1487	277	1490	305	1527	327	1530	353
	6	1200	310	1320	327	1347	334	1407	345	1420	369	1427	397	1460	431	1463	448
	8	1123	400	1273	423	1300	431	1360	445	1373	476	1377	511	1413	556	1417	578
	10			1227	495	1253	505	1313	521	1323	547	1327	573	1380	625	1383	651
	12					1207	592	1280	610	1293	640	1297	671	1330	732	1333	762
	16					1191	777	1248	793	1295	832	1263	872	1299	951	1301	991
FTSW11-250	0	1667		1700		1720		1733		1747		1753		1757		1760	
	2	1500	125	1600	128	1633	135	1664	142	1677	156	1697	171	1720	185	1723	199
	4	1417	239	1530	245	1563	259	1593	272	1607	299	1627	327	1650	353	1650	381
	6	1333	337	1460	355	1497	365	1527	374	1537	400	1558	430	1580	467	1583	486
	8	1250	433	1410	457	1445	469	1473	484	1483	515	1503	553	1527	602	1530	626
	10			1360	535	1393	549	1420	563	1433	591	1460	620	1493	676	1497	704
	12					1359	643	1387	660	1400	693	1420	727	1440	792	1443	825
	16					1307	833	1347	855	1360	898	1380	940	1403	1027	1407	1069

Installation dimension of bi-absorb twin screw pump

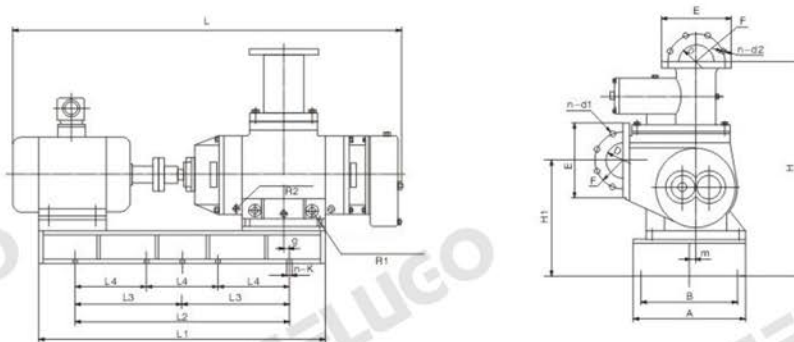

Model	Motor	Installation Dimension							Dimension of inlet and outlet						Hole		
		L	L1	L2-L4	A	B	n-K	H	H1	D	E	F	j-d	m	g	R1	R2
FTSWM2	Y112	1027	690	L2 500	260	230	4-12	474	240	50	165	125	4-M16 (Φ18)	20	-15	G1/12	G1/4
	Y132	1122	757	L2 550	280	245	4-14	503	269					28	-24		
	Y160	1265	895	L2 650	330	290	4-14	551	317					28	-42		
FTSWM3	Y132	1187	817	L2 600	300	270	4-14	516	275	65	185	145	8-M16 (Φ18)	23	-13	G1/12	G1/4
	Y160	1317	955	L2 600	330	290	4-14	566	325					33	-82		
	Y180	1382	998	L2 700	360	320	4-14	586	345					33	-54		
FTSWM4	Y132	1285	893	L2 600	315	285	4-14	560	310	80	200	160	8-M20 (Φ22)	21	-26	G1/12	G1/4
	Y160	1415	1017	L2 700	340	300	4-14	582	332					33	-38		
	Y180	1480	1060	L2 700	360	320	4-14	602	352					38	-60		
FTSWM5	Y160	1525	1092	L2 800	360	320	4-14	692	362	100	235	190	8-M24 (Φ27)	28	0	G3/4	G1/2
	Y180	1590	1135	L3 450	380	340	6-14	692	362					33	25		
	Y200	1655	1176	L3 500	400	360	6-18	736	406					43	55		
	Y225	1725	1235	L3 500	440	400	6-18	761	431					43	25		
FTSWM6	Y180	1738	1244	L3 500	420	380	6-18	796	436	150	300	250	8-M24 (Φ27)	27	53	G3/4	G1/2
	Y200	1803	1284	L3 500	440	400	6-18	796	436					37	33		
	Y225	1848	1344	L3 550	460	420	6-18	821	461					47	53		
	Y250	1958	1409	L3 600	490	440	6-18	866	506					54	71		
	Y280	2078	1534	L3 650	550	500	6-18	900	540					54	58		
FTSWM7	Y200	1910	1379	L3 580	514	470	6-18	947	516	200	360	310	12-M24 (Φ27)	17	90	G1	G1/2
	Y225	1955	1438	L3 580	524	480	6-18	947	516					22	60		
	Y250	2065	1505	L3 650	550	500	6-18	967	536					35	98		
	Y280	2185	1627	L3 700	580	530	6-18	1001	570					50	86		
	Y315	2385	1738	L4 500	640	590	8-24	1056	625					64	81		
FTSWM8	Y250	2230	1630	L3 700	610	560	6-18	1076	610	250	425	370	12-M27 (Φ30)	25	120	G1	G1/2
	Y280	2350	1752	L3 750	640	590	6-18	1076	610					40	109		
	Y315	2250	1863	L4 550	680	630	8-24	1111	645					60	129		
FTSWM9	Y280	2540	1884	L4 550	710	660	8-24	1265	740	300	485	430	16-M27 (Φ30)	25	153	G1	G1/2
	Y315	2740	2045	L4 600	750	690	8-24	1285	760					45	148		
	Y355	3190	2174	L4 650	810	750	8-24	1305	780					75	158		
FTSWM10	Y315	2860	2167	L4 650	810	750	8-27	1486	850	400	580	525	16-M27 (Φ30)	27	222	G11/2	G3/4
	Y355	3310	2296	L4 700	870	810	8-28	1506	870					57	232		
FTSWM11	Y500	4460	3400	L4 1000	1200	1130	8-27	1720	960	500/	715/	650/	20-M30	140	170	G11/2	G3/4
	Y560	4554	3550	L4 1000	1100	940	8-27	1720	960	450	640	585	(Φ30)	140	65		

According to the actual requirements of the contract to be the configuration of power after the entry into force, the company approved plans to provide details.

**FTSH Series Twin Screw Pump**

This series consists of medium and large-capacity double-suction twin screw pumps. It is available in two bearing configurations: internal bearing and external bearing. Optional configurations include a heating jacket and an integrated safety relief valve.

For the external bearing design, the bearing housing is completely isolated from the pump chamber by a mechanical seal and a radial shaft oil seal, ensuring excellent sealing performance. The pump offers high flow capacity, outstanding self-priming capability, low operating noise, and a long service life.

**NPSHr table of pumps**

Size	Speed n950r/min						Speed n1450r/min					
	Viscosity mm <sup>2</sup> /s						Viscosity mm <sup>2</sup> /s					
	≤35	75	150	350	750	1500	≤35	75	150	350	750	1500
NPSHr(m)												
280-20、28	1.6	1.6	1.6	1.6	1.6	1.6	1.6	1.6	1.7	1.7	1.7	1.8
280-40、56	1.7	1.7	1.7	1.8	1.8	1.9	1.9	1.9	2	2	2.1	2.3
560-25、34	1.6	1.6	1.6	1.7	1.7	1.7	1.7	1.7	1.7	1.8	1.8	1.9
560-50、72	1.8	1.8	1.8	1.9	2	2.1	2.1	2.1	2.2	2.3	2.4	2.6
800-30、40	1.6	1.7	1.7	1.7	1.8	1.8	1.8	1.8	1.8	1.9	1.9	2
800-60、80	1.9	1.9	2	2	2.1	2.3	2.2	2.3	2.4	2.6	2.7	3
1400-38、50	1.7	1.7	1.7	1.8	1.8	1.9	1.9	1.9	1.9	2	2.1	2.2
1400-75、96	2	2.1	2.2	2.3	2.4	2.6	2.6	2.7	2.8	3	3.3	3.6
2500-43、56	1.7	1.8	1.8	1.8	1.9	2	1.9	2	2	2.1	2.2	2.4
2500-85、112	2.2	2.2	2.3	2.4	2.6	2.8	2.8	3	3.1	3.4	3.7	4.1
4200-50、67	1.8	1.8	1.8	1.9	2	2.1	2.1	2.1	2.2	2.3	2.4	2.6
4200-100、128	2.4	2.4	2.5	2.7	2.9	3.2	3.3	3.4	3.6	4	4	4.8
7000-80、100	1.8	1.8	1.8	1.9	2	2.1	2.1	2.1	2.2	2.3	2.4	2.6
7000-128、150	2.4	2.4	2.5	2.7	2.9	3.2	3.3	3.4	3.6	4	4	4.8
9800-80、100	2.1	2.2	2.2	2.4	2.5	2.7	2.7	2.8	2.9	3.2	3.5	3.8
9800-128、150	2.5	2.6	2.8	3	3.2	3.5	3.7	3.8	4.1	4.5	4.9	5.5
9800-144、160	3.1	3.2	3.4	3.7	4.1	4.5	4.8	5.1	5.4	6.1	6.7	7.6
18000-128、160	2	2	2.2	2.2	2.5	2.5	2.2	2.2	2.5	2.5	3	3
18000-176、192、250	2.4	2.4	2.6	2.6	3	3	2.5	2.5	3	3	3.5	3.8

**FTSH Performance Parameters**

The performance table of main technique

Speed n=1450r/min

Size	ΔP (bar)	Viscosity (mm <sup>2</sup> /s)															
		1		15		35		75		150		350		750		1500	
		m <sup>3</sup> /h	KW	m <sup>3</sup> /h	KW	m <sup>3</sup> /h	KW	m <sup>3</sup> /h	KW	m <sup>3</sup> /h	KW	m <sup>3</sup> /h	KW	m <sup>3</sup> /h	KW	m <sup>3</sup> /h	KW
280-20	2	7.7	1.7	8	2	8.2	2.5	8.4	3	8.5	3.6	8.6	4.6	8.7	5.8	8.8	6.1
	4	6.9	2.2	7.4	2.6	7.7	3	8	3.5	8.2	4.2	8.4	5.2	8.5	6.4	8.6	7.1
	6	6.1	2.7	6.8	3.1	7.2	3.5	7.7	4.1	7.9	4.7	8.2	5.7	8.4	6.9	8.5	7.7
	8	5.4	3.2	6.3	3.6	6.9	4	7.3	4.6	7.7	5.2	8	6.2	8.2	7.4	8.4	8.2
	10	4.8	3.8	5.8	4.1	6.5	4.6	7	5.1	7.4	5.7	7.8	6.7	8.1	7.9	8.3	8.7
	12	4.3	4.5	5.4	4.7	6.1	5.1	6.8	5.6	7.2	6.3	7.6	7.3	7.9	8.5	8.2	9.2
	14	3.9	5.3	4.9	5.2	5.8	5.6	6.5	6.2	7	6.8	7.5	7.8	7.8	9	8	9.8
	16	3.2	5.1	4.5	5.7	5.6	6.1	6.3	6.7	6.9	7.3	7.4	8.3	7.7	9.5	8	10.3
	18	2.5	6	4.2	6.3	5.4	6.7	6.1	7.2	6.7	7.8	7.2	8.8	7.6	10	7.9	10.8
	20			3.8	7	5.1	7.3	5.9	7.7	6.5	8.4	7.1	9.4	7.5	10.6	7.8	11.3
	22					4.7	7.8	5.7	8.3	6.3	8.9	7	9.9	7.4	11.1	7.7	11.9
24							5.5	8.9	6.1	9.5	6.8	10.4	7.3	11.6	7.7	12.4	
280-28	2	10.5	1.9	10.9	2.3	11.2	2.8	11.4	3.3	11.5	4	11.7	5.1	11.8	6.4	11.9	7.2
	4	9.4	2.7	10	3.1	10.5	3.5	10.9	4.1	11.1	4.8	11.4	5.8	11.6	7.1	11.7	7.9
	6	8.4	3.4	9.3	3.8	9.9	4.2	10.4	4.8	10.8	5.5	11.1	6.5	11.3	7.8	11.5	8.6
	8	7.5	4.1	8.6	4.5	9.3	4.9	10	5.5	10.4	6.2	10.8	7.2	11.1	8.5	11.3	9.4
	10	6.7	4.9	8	5.2	8.8	5.6	9.6	6.2	10.1	6.9	10.6	8	11	9.2	11.2	10.1
	12	6	5.8	7.3	5.9	8.3	6.3	9.2	6.9	9.8	7.6	10.4	8.7	10.8	9.9	11.1	10.8
	14	5.1	6.2	6.8	6.7	7.9	7	8.8	7.6	9.5	8.3	10.2	9.4	10.6	10.7	10.9	11.5
	16			6.4	7.6	7.5	7.7	8.6	8.3	9.4	9	10	10.1	10.5	11.4	10.9	12.2
	18					7	8.5	8.4	9.1	9.1	9.7	9.9	10.8	10.4	12.1	10.7	12.9
	20							7.8	9.7	8.9	10.4	9.7	11.5	10.2	12.8	10.6	13.6
280-40	2	15.9	2.4	16.4	2.8	16.7	3.2	17	3.9	17.2	4.6	17.4	5.7	17.5	7.1	17.6	8
	4	14.4	3.4	15.3	3.8	15.9	4.3	16.3	4.9	16.7	5.7	17	6.8	17.2	8.1	17.3	9
	6	13.2	4.5	14.4	4.9	15.1	5.3	15.7	6	16.2	6.7	16.6	7.8	16.9	9.2	17.1	10.1
	8	12.1	5.5	13.5	5.9	14.4	6.4	15.2	7	15.8	7.8	16.3	8.9	16.7	10.2	16.9	11.1
	10			12.7	7	13.8	7.4	14.7	8	15.4	8.8	16	9.9	16.4	11.3	16.7	12.2
	12					13.2	8.5	14.2	9.1	15	9.8	15.7	11	16.2	12.3	16.6	13.2
	14							13.8	10.2	14.6	10.9	15.4	12	16	13.4	16.4	14.3
	16									14.4	11.9	15.3	13.1	15.9	14.4	16.3	15.3
280-56	2	22.3	2.9	23	3.4	23.4	3.9	23.8	4.6	24.1	5.4	24.3	6.7	24.5	8.2	24.6	9.1
	4	20.3	4.4	21.5	4.9	22.3	5.4	22.9	6.1	23.4	6.9	23.8	8.1	24.1	9.6	24.3	10.6
	6			20.2	6.3	21.3	6.8	22.1	7.5	22.7	8.3	23.3	9.6	23.7	11.1	24	12.1
	8							21.4	9	22.2	9.8	22.9	11.1	23.4	12.6	23.7	13.6
	10									21.6	11.3	22.5	12.5	23.1	14	23.5	15
560-25	2	15.5	2.5	16.1	3	16.4	3.6	16.7	4.3	16.9	5.1	17.1	6.4	17.3	8	17.4	9
	4	14	3.6	14.9	4.1	15.5	4.6	16	5.3	16.4	6.1	16.7	7.4	17	9	17.1	10
	6	12.7	4.6	13.9	5.1	14.7	5.6	15.4	6.3	15.9	7.2	16.3	8.4	16.7	10	16.9	11.1
	8	11.5	5.7	13	6.1	14	6.7	14.8	7.4	15.4	8.2	16	9.5	16.4	11.1	16.7	12.1
	10	10.3	6.7	12.1	7.1	13.3	7.7	14.3	8.4	15	9.3	15.7	10.6	16.1	12.1	16.5	13.1
	12	9.2	7.7	11.3	8.2	12.7	8.7	13.8	9.5	14.6	10.3	15.4	11.6	15.9	13.2	16.3	14.2
	14	8.2	8.8	10.5	9.2	12	9.8	13.3	10.5	14.2	11.3	15.1	12.6	15.7	14.2	16.1	15.2
	16	7.3	10.1	9.7	10.3	11.7	10.8	13	11.5	14	12.4	14.9	13.7	15.6	15.2	16	16.3
	18			8.9	11.5	11.1	11.9	12.6	12.6	13.7	13.4	14.7	14.7	15.4	16.3	15.9	17.3
	20					10.6	12.9	12.2	13.6	13.4	14.5	14.4	15.8	15.2	17.3	15.7	18.3
	22							11.8	14.7	13	15.5	14.2	16.8	15	18.3	15.6	19.4
	24							11.4	15.7	12.7	16.5	13.9	17.8	14.8	19.4	15.4	20.4

## FTSH Performance Parameters

The performance table of main technique

Speed n=1450r/min

Size	ΔP (bar)	Viscosity (mm <sup>2</sup> /s)															
		1		15		35		75		150		350		750		1500	
		m3/h	KW	m3/h	KW	m3/h	KW	m3/h	KW	m3/h	KW	m3/h	KW	m3/h	KW	m3/h	KW
560-34	2	21.6	3.1	22.2	3.6	22.7	4.2	23	5	23.3	5.9	23.5	7.3	23.7	9	23.8	10.2
	4	19.8	4.5	20.9	5	21.6	5.6	22.2	6.4	22.6	7.3	23	8.7	23.3	10.4	23.5	11.6
	6	18.3	5.9	19.7	6.4	20.7	7	21.5	7.8	22	8.7	22.6	10.2	22.9	11.9	23.2	13
	8	16.8	7.3	18.6	7.9	19.8	8.4	20.8	9.2	21.5	10.1	22.2	11.6	22.6	13.3	23	14.4
	10	15.5	8.7	17.6	9.3	19	9.8	20.2	10.6	21	11.6	21.8	13	22.3	14.7	22.7	15.8
	12	14.2	10.1	16.6	10.7	18.2	11.3	19.6	12.1	20.5	13	21.4	14.4	22.1	16.1	22.5	17.2
	14	13	11.6	15.7	12.1	17.5	12.7	19	13.5	20.1	14.4	21.1	15.8	21.8	17.5	22.3	18.7
	16			15.2	13.5	17.1	14.1	18.7	14.9	19.9	15.8	20.9	17.2	21.6	18.9	22.2	20.1
	18					16.5	15.5	18.2	16.3	19.4	17.2	20.6	18.7	21.4	20.4	22	21.5
	20						17.7	17.7	19.1	18.6	20.3	20.1	21.2	21.8	21.8	22.9	
560-50	2	32.2	4	33	4.6	33.6	5.3	34	6.2	34.4	7.3	34.7	9	34.9	10.9	35	12.3
	4	29.8	6.1	31.2	6.7	32.2	7.4	32.9	8.3	33.5	9.4	34	11	34.4	13	34.6	14.3
	6	27.8	8.2	29.7	8.8	30.9	9.5	32	10.4	32.7	11.5	33.4	13.1	33.9	15.1	34.3	16.4
	8	25.9	10.3	28.3	10.9	29.8	11.5	31.1	12.5	32	13.5	32.9	15.2	33.5	17.2	33.9	18.5
	10	24.1	12.3	26.9	13	28.7	13.6	30.3	14.6	31.4	15.6	32.4	17.3	33.1	19.3	33.6	20.6
	12			25.6	15	27.7	15.7	29.5	16.6	30.7	17.7	31.9	19.4	32.8	21.4	33.4	22.7
	14					26.8	17.8	28.7	18.7	30.2	19.8	31.5	21.5	32.4	23.4	33.1	24.8
	16						28.3	20.8	29.8	21.9	31.2	23.5	32.2	25.5	32.9	26.8	
560-72	2	46.1	5.2	47.4	6	48.2	6.8	48.8	7.8	49.3	9.1	49.8	11.1	50.1	13.4	50.3	14.9
	4	42.7	8.2	44.7	9	46.1	9.8	47.2	10.8	48.1	12.1	48.8	14	49.3	16.4	49.7	17.9
	6			42.4	12	44.3	12.8	45.8	13.8	46.9	15.1	48	17	48.7	19.4	49.2	20.9
	8					42.6	15.7	44.5	16.8	46	18.1	47.2	20	48.1	22.4	48.7	23.9
	10							43.3	19.8	44.9	21.1	46.5	23	47.5	25.4	48.3	26.9
800-30	2	28	5	28.7	6	29.1	7.2	29.4	8.7	29.7	10.5	30	13.3	30.1	16.7	30.3	18.8
	4	26.1	6.8	27.2	7.8	28	9	28.6	10.5	29	12.3	29.4	15.1	29.7	18.4	29.9	20.6
	6	24.5	8.6	26	9.6	27	10.7	28.8	12.3	28.4	14.1	29	16.8	29.4	20.2	29.7	22.4
	8	23	10.4	24.9	11.4	26.1	12.5	27.1	14.1	27.9	15.9	28.6	18.6	29	22	29.4	24.1
	10	21.6	12.2	23.8	13.2	25.3	14.3	26.5	15.9	27.4	17.7	28.2	20.4	28.7	23.7	29.1	25.9
	12	20.2	14	22.8	15	24.5	16.1	25.9	17.7	26.9	19.5	27.8	22.2	28.5	25.5	28.9	27.7
	14	19.8	16.1	21.8	16.8	23.7	17.9	25.3	19.5	26.4	21.3	27.4	24	28.2	27.3	28.7	29.5
	16	18.7	17.3	21.3	18.6	23.3	19.7	24.9	21.3	26.1	23.1	27.2	25.8	28	29.1	28.6	31.3
	18			20.8	20.6	22.6	21.5	24.4	23.1	25.7	24.8	26.9	27.6	27.8	30.9	28.4	33.1
	20					22	23.3	23.9	24.9	25.3	26.6	26.6	29.4	27.5	32.7	28.2	34.9
	22							23.4	26.7	24.9	28.4	26.3	31.2	27.3	34.5	28	36.7
	24							23	28.4	24.6	30.2	26.1	33	27.1	36.3	27.8	38.5
800-40	2	37.7	5.8	38.5	6.9	39	8.1	39.5	9.7	39.8	11.6	40.1	14.6	40.3	18.1	40.4	20.4
	4	35.4	8.2	36.8	9.3	37.7	10.5	38.4	12.1	38.9	14	39.4	17	39.8	20.5	40	22.8
	6	33.4	10.6	35.3	11.7	36.5	12.9	37.5	14.5	38.2	16.4	38.9	19.4	39.4	22.9	39.7	25.2
	8	31.6	13	33.9	14.1	35.4	15.3	36.6	16.9	37.5	18.8	38.4	21.8	39	25.3	39.4	27.6
	10	29.9	15.4	32.6	16.5	34.4	17.7	35.8	19.3	36.9	21.2	37.9	24.2	38.6	27.7	39.1	30
	12	28.3	18.2	31.4	18.9	33.4	20.1	35.1	21.7	36.3	23.6	37.4	26.6	38.3	30.1	38.8	32.4
	14	26.4	19.6	30.2	21.3	32.5	22.5	34.4	24.1	35.7	26	37	29	37.9	32.5	38.5	34.8
	16			29.1	24	31.9	24.8	34	26.5	35.4	28.4	36.8	31.4	37.7	34.9	38.4	37.2
	18					31.3	27.3	33.3	28.9	34.9	30.8	36.4	33.8	37.4	37.3	38.2	39.6
	20							32.7	31.3	34.4	33.2	36	36.2	37.1	39.7	37.9	42

**FTSH Performance Parameters**

The performance table of main technique

Speed n=1450r/min

Size	ΔP (bar)	Viscosity (mm <sup>2</sup> /s)															
		1		15		35		75		150		350		750		1500	
		m3/h	KW	m3/h	KW	m3/h	KW	m3/h	KW	m3/h	KW	m3/h	KW	m3/h	KW	m3/h	KW
800-60	2	56.9	7.4	58	8.7	58.7	10	59.3	11.9	59.8	14	60.2	17.4	60.5	21.4	60.7	24
	4	53.8	11	55.7	12.3	56.9	13.6	57.9	15.5	58.6	17.6	59.3	21	59.8	25	60.1	27.6
	6	51.1	14.6	53.7	15.9	55.3	17.2	56.7	19.1	57.6	21.2	58.6	24.6	59.2	28.5	59.7	31.2
	8			51.8	19.5	53.8	20.8	55.5	22.7	56.7	24.8	57.9	28.2	58.7	32.1	59.2	34.8
	10			50	23.1	52.4	24.4	54.4	26.3	55.9	28.4	57.2	31.8	58.2	35.7	58.8	38.4
	12					51.1	28	53.4	29.8	55	32	56.6	35.3	57.7	39.3	58.5	42
	14							52.4	33.4	54.3	35.6	56	38.9	57.2	42.9	58.1	45.6
	16									53.8	39.2	55.6	42.5	57	46.5	57.9	49.1
800-80	2	74.6	9.1	76.4	10.5	77.6	12	78.6	14.1	79.3	16.5	79.9	20.2	80.4	24.6	80.7	27.6
	4	69.5	13.9	72.6	15.3	74.6	16.8	76.2	18.9	77.4	21.3	78.5	25	79.3	29.4	79.9	32.4
	6			69.2	20.1	71.9	21.6	74.2	23.6	75.8	26.1	77.3	29.8	78.4	34.2	79.1	37.2
	8					69.5	26.4	72.3	28.4	74.3	30.8	76.2	34.6	77.5	39	78.4	42
	10							70.5	33.2	72.9	35.6	75.1	39.4	76.6	43.8	77.7	46.8
1400-38	2	53.7	6.6	54.6	7.6	55.2	8.7	55.7	10.3	56.1	12	56.4	14.8	56.7	18.1	56.8	20.3
	4	51.1	9.9	52.6	11	53.7	12.1	54.5	13.6	55.1	15.4	55.7	18.2	56.1	21.5	56.4	23.7
	6	48.8	13.3	50.9	14.3	52.3	15.4	53.4	17	54.3	18.8	55.1	21.5	55.6	24.8	56	27
	8	46.7	16.6	49.3	17.7	51	18.8	52.5	20.3	53.5	22.1	54.5	24.9	55.1	28.2	55.6	30.4
	10	44.8	20	47.9	21	49.9	22.2	51.6	23.7	52.8	25.5	53.9	28.3	54.7	31.6	55.3	33.8
	12	42.9	23.4	46.5	24.4	48.8	25.5	50.7	27.1	52.1	28.8	53.4	31.6	54.3	34.9	55	37.1
	14	41.1	27.4	45.1	27.8	47.7	28.9	49.9	30.4	51.4	32.2	52.9	35	53.9	38.3	54.7	40.5
	16	38.9	29.2	43.7	31.6	47.1	32.2	49.4	33.8	51.1	35.6	52.6	38.3	53.7	41.7	54.5	43.8
	18			41.3	33.1	46.2	35.6	48.7	37.1	50.5	38.9	52.2	41.7	53.4	45	54.2	47.2
	20					45.3	39.3	48	40.5	50	42.3	51.8	45.1	53.1	48.4	54	50.6
	22							47.3	43.9	49.4	45.6	51.4	48.4	52.7	51.7	53.7	53.9
	24									48.9	49	51	51.8	52.4	55.1	53.5	57.3
1400-50	2	71.3	8	72.4	9.2	73.1	10.4	73.6	12.2	74	14.2	74.4	17.3	74.7	21	74.9	23.5
	4	68.4	12.4	70.2	13.6	71.3	14.9	72.3	16.6	73	18.6	73.6	21.7	74	25.5	74.4	27.9
	6	65.9	16.9	78.2	18	69.8	19.3	71.1	21	72	23	72.9	26.2	73.5	29.9	73.9	32.3
	8	63.5	21.3	66.5	22.5	68.4	23.7	70	25.4	71.2	27.5	72.2	30.6	73	34.3	73.5	36.8
	10	61.3	25.7	64.8	26.9	67.1	28.1	69	29.9	70.3	31.9	71.6	35	72.5	38.7	73.2	41.2
	12	59.2	31	63.2	31.3	65.8	32.6	68	34.3	69.6	36.3	71	39.4	72	43.1	72.8	45.6
	14	56.5	33.6	61.7	35.7	64.6	37	67.1	38.7	68.8	40.7	70.5	43.8	74.6	47.6	72.5	50
	16			60.2	40.7	64	41.4	66.5	43.1	68.4	45.1	70.2	48.3	71.4	52	72.3	54.5
	18					63.4	46.3	65.7	47.6	67.8	49.6	69.7	52.7	71	56.4	72	58.9
	20							64.9	52.5	67.2	54	69.2	57.1	70.6	60.8	71.7	63.3
1400-75	2	106.8	10.9	108.4	12.3	109.5	13.8	110.3	15.9	111	18.3	111.6	22	112	26.5	112.3	29.4
	4	102.2	17.6	105	19	106.7	20.5	108.2	22.5	109.3	24.9	110.3	28.7	111	33.1	111.5	36
	6	98.2	24.2	102	25.6	104.4	27.1	106.4	29.2	107.8	31.6	109.2	35.3	110.2	39.7	110.8	42.7
	8	94.3	33.3	99.2	32.2	102.2	33.7	104.7	35.8	106.5	38.2	108.2	41.9	109.3	46.4	110.2	49.3
	10			96.6	38.9	100.1	40.4	103.1	42.4	105.2	44.8	107.2	48.6	108.6	53	109.6	56
	12					98.2	47	101.6	40.1	104	51.5	106.3	55.2	107.9	59.6	109	62.6
	14							100.1	55.7	102.7	58.1	105.4	61.8	107.2	66.3	108.5	69.2
	16									102.2	64.7	104.9	68.5	106.8	72.9	108.2	75.9
1400-96	2	134.7	13.3	137.3	14.8	138.9	16.5	140.3	18.8	141.3	21.5	142.2	25.7	142.9	30.6	143.4	33.9
	4	127.6	21.7	131.9	23.3	134.6	25	137	27.3	138.7	30	140.2	34.2	141.3	39.1	142.1	42.4
	6			127.1	31.8	130.9	33.5	134.1	35.8	136.4	38.5	138.5	42.7	140	47.6	141.1	50.9
	8					127.2	38.7	131.4	44.3	134.2	47	136.9	51.1	138.7	56.1	140.1	59.4
	10							127.6	49.5	132.3	55.5	135.4	59.6	137.6	64.6	139.1	67.9

## FTSH Performance Parameters

The performance table of main technique

Speed n=1450r/min

Size	ΔP (bar)	Viscosity (mm <sup>2</sup> /s)															
		1		15		35		75		150		350		750		1500	
		m <sup>3</sup> /h	KW	m <sup>3</sup> /h	KW	m <sup>3</sup> /h	KW	m <sup>3</sup> /h	KW	m <sup>3</sup> /h	KW	m <sup>3</sup> /h	KW	m <sup>3</sup> /h	KW	m <sup>3</sup> /h	KW
2500-43	2	85.5	11.2	87	13	87.9	15.1	88.7	17.8	89.3	21.1	89.8	26.1	90.2	32.1	90.5	36.1
	4	81.5	16.5	83.9	18.4	85.5	20.4	86.8	23.2	87.8	26.4	88.7	31.5	89.3	37.5	89.8	41.4
	6	77.9	21.9	81.2	23.7	83.4	25.8	85.2	28.5	86.5	31.8	87.7	36.8	88.5	42.8	89.2	46.8
	8	74.7	27.2	78.8	29.1	81.4	31.1	83.7	33.9	85.3	37.1	86.8	42.2	87.8	48.2	88.6	52.1
	10	71.6	32.6	76.5	34.4	79.6	36.5	82.2	39.2	84.2	42.5	85.9	47.5	87.2	53.5	88.1	57.5
	12	68.7	37.9	74.3	39.8	77.9	41.8	80.9	44.6	83.1	47.8	85.1	52.9	86.5	58.9	87.6	62.8
	14	65.9	43.3	72.2	45.1	76.2	47.2	79.6	49.9	85	53.2	84.3	58.2	85.9	64.2	87.1	68.2
	16	62.3	47	71	50.5	75.3	52.5	78.9	55.3	84.5	58.5	83.9	63.6	85.6	69.6	86.8	73.5
	18	57.8	51.4	69.2	55.8	73.8	57.9	77.8	60.6	80.6	63.9	83.2	68.9	85.1	74.9	86.4	78.9
	20			67.4	61.2	72.5	63.2	76.7	66	79.7	69.2	82.6	74.3	84.6	80.3	86	84.2
	22					71.1	68.6	75.6	71.3	78.9	74.6	82	79.6	84.1	85.6	85.6	89.6
24							74.6	76.7	78.1	79.9	81.3	85	83.6	91	85.2	94.9	
2500-56	2	111.4	13.4	113.3	15.4	114.5	17.7	115.5	20.7	116.3	24.3	117	29.9	117.5	36.5	117.8	40.9
	4	106.1	20.3	109.3	22.4	111.4	24.6	113.1	27.7	114.3	31.3	115.5	36.9	116.3	43.5	116.9	47.9
	6	101.5	27.3	105.8	29.4	108.6	31.6	110.9	34.7	112.6	38.3	114.2	43.8	115.3	50.4	116.1	54.8
	8	97.3	34.3	102.6	36.3	106.1	38.6	109	41.6	111.1	45.2	113	50.8	114.4	57.39	115.4	61.8
	10	93.3	41.2	99.6	43.3	103.7	45.5	107.1	48.6	109.6	52.2	111.9	57.8	113.5	64.4	114.7	68.8
	12	89.5	49.5	96.7	50.3	101.4	52.5	105.4	55.6	108.2	59.2	110.9	64.7	112.7	71.3	114	75.7
	14	84.7	56.3	93.8	58.4	99.3	59.5	103.7	62.5	106.9	66.1	109.8	71.7	111.9	78.3	113.4	82.7
	16			88.5	65.5	91.4	67.4	102.7	69.5	106.1	73.1	109.3	78.7	111.5	85.3	113.1	89.7
	18					81.8	75.2	101.8	77.3	105	80.1	108.4	85.6	110.8	92.2	112.5	96.6
	20							98.1	85	103.9	87	107.6	92.6	110.2	99.2	112	103.6
2500-85	2	169	18.1	171.9	20.5	173.8	23.1	175.4	26.7	176.5	30.9	177.6	37.4	178.3	45.2	178.8	50.3
	4	160.9	28.7	165.8	31.1	168.9	33.7	171.6	37.3	173.5	41.5	175.3	48	176.5	55.8	177.4	60.9
	6	153.8	39.2	160.4	41.7	164.7	44.3	168.3	47.9	170.9	52.1	173.3	58.6	175	66.3	176.2	71.5
	8	147	53.5	155.5	52.2	160.8	54.9	165.3	58.5	168.5	62.6	171.5	69.2	173.6	76.9	175.1	82.1
	10			150.7	65.3	157.1	65.4	162.4	69	166.2	73.2	169.7	79.7	172.3	87.5	174	92.6
	12					153.5	77.9	159.7	79.6	164.1	83.8	168.1	90.3	171	98.1	173	103.2
	14							157.1	91.8	162	94.4	166.6	100.9	169.8	108.7	172.1	113.8
	16									160.9	105	165.7	111.5	169.1	119.2	171.5	124.4
2500-112	2	223.4	22.6	227	25.4	229.4	28.5	231.4	32.7	232.8	37.5	234.1	45.1	235	54.1	235.7	60
	4	213.3	36.6	219.4	39.4	223.3	42.4	222.6	46.6	229	51.5	231.3	59.1	232.8	68	234	74
	6			212.7	53.3	218	56.4	222.5	60.5	225.8	65.4	228.8	73	230.9	81.9	232.4	87.9
	8			206.2	72.1	212.8	75.1	218.7	74.5	222.8	79.3	226.5	89.9	229.1	95.9	231	101.8
	10							215	91.7	219.9	93.3	224.4	100.8	227.5	109.8	229.7	115.8
4200-50	2	154.1	21.6	155.9	25.6	157.1	29.9	158	35.7	158.8	42.5	159.4	53.1	159.9	65.7	160.2	74.1
	4	149	31.1	152.1	35	154	39.3	155.7	45.2	156.9	52	158	62.6	158.8	75.2	159.3	83.5
	6	144.6	40.5	148.7	44.5	151.4	48.8	153.6	54.6	155.5	61.4	156.8	72	157.8	84.6	158.6	93
	8	140.5	50	145.6	53.9	148.9	58.2	151.7	64	153.7	70.9	155.6	81.5	156.9	94.1	157.9	102.4
	10	136.6	59.4	142.7	63.4	146.7	67.6	150	73.5	152.3	80.3	154.6	90.9	156.1	103.5	157.2	111.9
	12	133	68.9	140	72.8	144.5	77.1	148.3	82.9	151	89.7	153.5	100.4	155.3	113	156.6	121.3
	14	129.5	78.3	137.3	82.3	142.4	86.5	146.6	92.4	149.7	99.2	152.6	109.8	154.6	122.4	156	130.8
	16	127.6	87.8	135.9	91.7	141.2	96	145.7	401.8	149	108.6	152	119.2	154.2	131.9	155.7	140.2
	18	124.6	97.2	133.6	101.1	139.4	105.4	144.4	111.3	147.9	118.1	151.2	128.7	153.5	141.3	155.1	149.7
	20			131.4	110.6	137.7	114.9	143	120.7	146.8	127.5	150.4	138.1	152.9	150.7	154.6	159.1
	22					136	124.3	141.7	130.2	145.8	137	149.6	147.6	152.3	160.2	154.2	168.5
	24							140.4	139.6	144.8	146.4	148.8	157	151.7	169.6	153.7	178

**FTSH Performance Parameters**

The performance table of main technique

Speed n=1450r/min

Size	ΔP (bar)	Viscosity (mm <sup>2</sup> /s)															
		1		15		35		75		150		350		750		1500	
		m <sup>3</sup> /h	KW	m <sup>3</sup> /h	KW	m <sup>3</sup> /h	KW	m <sup>3</sup> /h	KW	m <sup>3</sup> /h	KW	m <sup>3</sup> /h	KW	m <sup>3</sup> /h	KW	m <sup>3</sup> /h	KW
4200-67	2	206	26	209	30	210	34	211	40	212	47	213	59	214	72	217	81
	4	200	38	204	42	206	47	208	51	210	60	211	71	212	84	213	93
	6	194	51	199	55	203	59	206	66	208	73	210	84	211	97	212	106
	8	189	63	196	68	200	72	203	78	206	85	208	96	210	110	211	118
	10	184	76	192	80	197	85	201	91	204	98	207	109	209	122	210	131
	12	179	89	188	93	194	97	199	104	202	111	206	122	208	135	210	144
	14	175	101	185	106	191	110	197	116	201	123	204	134	207	148	209	156
	16			183	118	190	123	196	129	200	136	204	147	206	160	208	169
	18			180	131	188	135	194	141	198	149	203	160	206	173	208	182
	20				185	148	192	154	197	161	202	172	205	186	207	194	
4200-100	2	305	33	309	37	312	42	314	48	316	56	318	68	319	82	320	91
	4	293	52	300	56	305	61	309	67	312	75	314	87	316	101	317	110
	6	283	70	292	75	299	80	304	86	308	94	311	106	314	120	316	129
	8	273	89	285	94	293	99	300	106	304	113	309	125	312	139	314	148
	10	264	108	278	113	288	117	295	124	301	132	306	144	310	158	312	167
	12			272	132	282	136	291	143	298	151	304	162	308	177	311	186
	14					277	155	287	162	295	169	301	181	306	195	310	205
	16						285	181	293	188	300	200	305	214	309	224	
4200-128	2	385	39	392	44	396	49	400	57	402	65	405	78	407	93	408	104
	4	366	63	377	68	385	73	391	81	395	89	400	102	403	118	405	128
	6	349	88	365	92	375	98	383	105	389	113	395	126	399	142	402	152
	8	334	112	353	117	366	122	376	129	384	134	391	150	396	166	399	176
	10			342	141	357	146	369	153	378	162	387	175	393	190	397	200
7000-80	2	366	25	368	28	369	30	370	30	371	36	372	45	373	50	373	55
	4	348	48	350	52	352	56	354	56.6	355	68	356	80	357	93	357	105
	6	334	68	337	75	340	82	343	82.3	344	100	345	116	346	134	346	150
	8	318	85	322	96	327	106	331	106	332	127	333	148	334	170	334	190
	10	300	103	308	116	314	128	319	128	320	154	321	180	322	205	322	230
	12	278	118	290	133	300	147	307	147	320	177	309	206	310	235	310	265
	14			278	150	288	165	295	165	296	200	297	230	298	265	298	295
	16			265	165	276	182	284	182	284	220	285	255	286	290	287	325
	18					254	192	266	192	268	235	270	270	272	307	274	345
	20					230	195	244	195	247	240	250	273	253	312	256	350
	22							222	197	225	245	229	276	233	315	237	355
	24							185	200	190	250	195	280	200	320	205	360
7000-100	2	466	32	468	35	469	37	470	37.6	471	46	472	55	473	63	473	70
	4	438	60	441	65	443	71	445	71.2	446	87	447	102	448	115	448	130
	6	424	83	425	95	428	103	430	103	431	125	432	145	433	165	433	185
	8	406	107	410	120	413	133	415	133	416	160	417	186	418	212	419	240
	10	388	128	393	145	397	160	400	160	401	195	402	225	404	256	406	285
	12	373	148	378	168	382	185	386	185	388	225	390	260	393	296	396	330
	14			352	186	362	206	368	206	370	250	373	290	377	330	380	370
	16			328	205	342	227	354	227	357	280	360	320	364	363	368	405
	18					324	244	338	244	341	300	344	342	347	390	350	440
	20					295	250	310	250	314	330	318	350	342	400	345	450
7000-128	2	590	40	595	45	598	48	600	48	601	58	603	70	605	80	608	90
	4	565	75	570	85	572	92	574	92	575	112	577	130	580	150	582	165
	6	545	108	550	120	553	133	555	133	557	160	560	188	563	212	567	240
	8	525	138	530	155	533	172	536	172	538	208	540	240	543	275	547	310
	10	500	166	508	186	513	207	517	207	520	250	523	290	526	330	530	370
	12	480	192	486	216	493	240	498	240	500	290	503	336	506	384	510	430
	14			450	240	462	265	470	265	472	320	475	370	478	420	482	475
16					420	290	430	290	432	350	435	406	438	460	442	520	

## FTSH Performance Parameters

The performance table of main technique

Speed n=1450r/min

Size	ΔP (bar)	Viscosity (mm <sup>2</sup> /s)															
		1		15		35		75		150		350		750		1500	
		m <sup>3</sup> /h	KW	m <sup>3</sup> /h	KW	m <sup>3</sup> /h	KW	m <sup>3</sup> /h	KW	m <sup>3</sup> /h	KW	m <sup>3</sup> /h	KW	m <sup>3</sup> /h	KW	m <sup>3</sup> /h	KW
7000-150	2	710	50	715	55	718	60	720	60	722	72	725	85	728	100	732	110
	4	665	90	672	100	676	110	679	110	681	132	685	155	690	176	695	200
	6	610	125	622	140	630	155	635	155	637	186	640	218	645	248	650	280
	8	570	160	582	180	592	200	590	200	593	240	597	280	603	320	610	360
	10	500	192	520	216	535	240	545	240	550	290	555	336	562	380	570	430
7000-160	2	760	60	765	63	768	67	770	68	772	81	775	94	778	105	782	117
	4	715	113	722	120	726	126	729	129	731	153	735	178	740	201	745	224
	6	660	157	672	167	680	177	685	181	687	216	690	250	695	283	700	315
	8	620	197	632	210	642	223	640	226	643	270	647	313	653	354	660	396
	10	550	218	570	236	585	254	595	262	600	314	605	365	612	415	620	465
9800-80	2	553	55	560	62	564	70	567	81	570	94	572	110	573	125	574	138
	4	536	87	546	94	553	102	559	113	563	126	567	143	569	157	570	171
	6	520	119	534	127	544	135	552	146	558	159	562	175	565	189	567	203
	8	506	151	524	159	535	167	545	178	552	191	558	207	561	221	564	235
	10	492	184	513	191	527	199	539	210	547	223	554	239	558	253	561	267
	12	479	216	504	223	520	231	533	242	543	255	550	271	555	286	558	299
	14	467	248	494	255	512	264	527	275	538	287	547	304	552	318	555	332
	16	455	280	488	288	505	296	522	307	534	320	543	336	549	350	553	364
	18	444	313	477	320	498	328	516	339	529	352	540	368	546	382	550	396
	20			468	352	492	360	511	371	525	384	536	400	543	415	548	428
	22					485	392	506	403	521	416	533	433	540	447	545	461
24							501	436	517	449	530	465	538	479	543	493	
9800-100	2	664	65	672	74	677	83	681	96	684	111	687	130	688	147	689	163
	4	642	104	655	113	664	122	671	135	676	150	680	169	683	186	685	202
	6	622	143	640	151	652	161	662	174	669	189	675	208	678	225	680	241
	8	604	181	627	190	641	200	654	213	662	228	669	247	674	263	677	280
	10	587	220	614	229	631	238	646	251	656	266	665	285	669	302	673	318
	12	571	259	602	268	622	277	638	290	650	305	660	324	665	341	669	357
	14	556	298	590	306	612	316	631	329	645	344	655	363	662	380	666	396
	16	541	336	579	345	604	354	624	367	639	382	651	402	658	418	663	434
	18			568	384	595	393	618	406	634	421	647	440	654	457	660	473
	20					587	432	611	445	629	460	643	479	651	496	657	512
	22							605	484	624	499	639	518	648	534	654	551
9800-128	2	772	76	782	86	789	97	794	111	798	129	801	151	803	170	805	188
	4	744	121	761	131	772	142	784	157	788	174	793	196	796	215	798	234
	6	719	166	742	176	757	187	769	202	779	219	786	241	790	260	793	279
	8	696	211	725	221	743	232	759	247	770	264	779	286	784	305	788	324
	10	674	257	708	267	730	278	749	292	762	310	773	331	779	351	784	369
	12	657	302	693	312	718	323	739	338	755	355	767	377	774	396	779	415
	14	634	347	678	357	707	368	730	383	748	400	761	422	769	441	775	460
	16					695	413	722	428	741	445	756	467	765	486	771	505
	18							713	473	734	491	750	512	760	532	767	550
9800-150	2	992	98	1005	111	1014	125	1021	144	1026	166	1030	194	1032	219	1034	243
	4	956	156	978	169	992	183	1004	202	1012	224	1019	252	1023	277	1026	301
	6	924	214	953	227	973	241	989	260	1001	282	1010	310	1015	335	1019	359
	8	894	272	931	285	955	299	975	318	990	340	1001	369	1008	393	1013	417
	10	867	330	910	343	939	357	962	376	980	399	993	427	1001	451	1007	475
	12	840	388	891	401	923	415	950	434	970	457	986	485	995	510	1001	534
9800-160	2	1062	105	1075	119	1084	134	1091	154	1096	177	1100	207	1102	234	1104	259
	4	1026	167	1048	182	1062	196	1074	216	1082	239	1089	269	1093	296	1096	322
	6	994	237	1023	245	1043	258	1059	278	1071	302	1080	331	1085	358	1089	384
	8	964	293	1001	306	1025	321	1045	341	1060	364	1071	395	1078	420	1083	446
	10	937	357	980	368	1009	384	1032	403	1050	428	1063	457	1071	483	1077	508
	12	910	420	961	433	993	446	1020	466	1040	490	1056	519	1065	546	1071	571

**FTSH Performance Parameters**

The performance table of main technique

Speed n=1450r/min

Size	ΔP (bar)	Viscosity (mm <sup>2</sup> /s)															
		1		15		35		75		150		350		750		1500	
		m <sup>3</sup> /h	KW	m <sup>3</sup> /h	KW	m <sup>3</sup> /h	KW	m <sup>3</sup> /h	KW	m <sup>3</sup> /h	KW	m <sup>3</sup> /h	KW	m <sup>3</sup> /h	KW	m <sup>3</sup> /h	KW
18000-176	0	1700		1750		1780		1800		1815		1820		1825		1830	
	2	1530	111	1645	127	1673	136	1728	148	1742	164	1747	179	1789	199	1793	215
	4	1445	210	1575	242	1602	260	1656	283	1670	314	1674	343	1716	381	1720	412
	6	1360	300	1505	350	1531	364	1584	388	1597	419	1602	452	1643	503	1647	525
	8	1275	375	1453	451	1477	468	1530	500	1543	540	1547	581	1583	647	1592	676
	10			1400	539	1424	554	1476	586	1488	620	1492	651	1533	730	1537	762
	12					1388	648	1440	686	1452	726	1456	763	1497	855	1501	893
	16					1353	842	1404	891	1416	944	1420	992	1460	1112	1464	1162
18000-192	0	1850		1900		1952		2000		2020		2030		2035		2040	
	2	1665	121	1786	137	1835	149	1920	164	1939	182	1949	200	1994	222	1999	239
	4	1573	229	1710	263	1757	285	1840	315	1858	349	1868	383	1913	425	1918	459
	6	1480	326	1634	380	1679	399	1760	431	1778	466	1786	503	1832	561	1836	585
	8	1388	386	1577	490	1620	513	1700	556	1717	600	1726	649	1770	723	1775	754
	10			1520	573	1562	601	1640	651	1656	690	1665	727	1709	814	1714	850
	12					1523	703	1600	762	1616	808	1624	851	1669	954	1673	996
	16					1484	923	1560	990	1576	1051	1583	1106	1628	1240	1632	1295
18000-224	0	2250		2300		2350		2400		2420		2430		2435		2440	
	2	2025	168	2160	177	2210	185	2300	197	2320	216	2330	238	2385	256	2390	276
	4	1910	321	2070	340	2115	359	2210	378	2230	415	2235	457	2290	491	2295	529
	6	1800	465	1980	491	2020	501	2110	517	2130	553	2140	595	2190	646	2195	672
	8	1685	600	1910	634	1950	647	2040	667	2060	714	2065	767	2120	834	2125	867
	10			1840	743	1880	758	1970	782	1985	821	1990	860	2070	938	2075	977
	12					1810	888	1920	915	1940	960	1945	1006	1995	1098	2000	1143
	16					1786	1165	1872	1189	1888	1248	1895	1308	1948	1427	1952	1486
18000-250	0	2500		2550		2580		2600		2620		2630		2635		2640	
	2	2250	187	2400	192	2450	202	2496	213	2515	234	2545	256	2580	277	2585	298
	4	2125	359	2295	367	2345	388	2390	408	2410	449	2440	490	2475	530	2475	571
	6	2000	505	2190	533	2245	547	2290	561	2305	600	2337	645	2370	700	2375	729
	8	1875	650	2115	686	2167	704	2210	722	2225	773	2255	830	2290	903	2295	939
	10			2040	802	2090	823	2130	845	2150	887	2190	930	2240	1014	2245	1056
	12					2038	965	2080	990	2100	1040	2130	1090	2160	1188	2165	1238
	16					1960	1250	2020	1283	2040	1347	2070	1410	2105	1540	2110	1603

## FTSH Performance Parameters

The performance table of main technique

Speed n=950r/min

Size	ΔP (bar)	Viscosity (mm <sup>2</sup> /s)															
		1		15		35		75		150		350		750		1500	
		m <sup>3</sup> /h	KW	m <sup>3</sup> /h	KW	m <sup>3</sup> /h	KW	m <sup>3</sup> /h	KW	m <sup>3</sup> /h	KW	m <sup>3</sup> /h	KW	m <sup>3</sup> /h	KW	m <sup>3</sup> /h	KW
280-20	2	4.6	1	4.9	1.2	5.1	1.4	5.3	1.8	5.4	2.1	5.5	2.7	5.6	3.4	5.7	3.8
	4	3.8	1.3	4.3	1.6	4.6	1.8	4.9	2.1	5.1	2.5	5.3	3	5.4	3.7	5.5	4.2
	6	3	1.7	3.7	1.9	4.2	2.1	4.6	2.4	4.8	2.8	5.1	3.4	5.3	4.1	5.4	4.5
	8			3.2	2.2	3.8	2.5	4.2	2.8	4.6	3.2	4.9	3.7	5.1	4.4	5.3	4.8
	10			2.7	2.6	3.4	2.8	3.9	3.1	4.3	3.5	4.7	4.1	4.9	4.7	5.2	5.2
	12					3	3.2	3.7	3.5	4.1	3.8	4.5	4.4	4.8	5.1	5.1	5.5
	14							3.4	3.8	3.9	4.2	4.4	4.8	4.7	5.4	5	5.9
	16							3.2	4.2	3.8	4.5	4.3	5.1	4.6	5.8	4.9	6.2
	18									3.6	4.9	4.1	5.4	4.5	6.1	4.8	6.6
	20									3.4	5.2	4	5.8	4.4	6.5	4.7	6.9
	22											3.9	6.1	4.3	6.8	4.6	7.3
24											3.8	6.5	4.2	7.1	4.5	7.6	
280-28	2	6.3	1.2	6.7	1.4	7	1.6	7.2	2	7.4	2.4	7.5	3	7.6	3.7	7.7	4.2
	4	5.2	1.6	5.9	1.9	6.3	2.1	6.7	2.4	6.9	2.8	7.2	4.3	7.4	4.2	7.5	4.6
	6	4.2	2.1	5.1	2.3	5.7	2.6	6.2	2.9	6.6	3.3	6.9	3.9	7.1	4.6	7.3	5.1
	8	3.3	2.6	4.4	2.8	5.2	3	5.8	3.4	6.2	3.8	6.7	4.4	6.9	5.1	7.2	5.6
	10			3.8	3.3	4.6	3.5	5.4	3.8	5.9	4.2	6.4	4.8	6.8	5.6	7	6
	12					4.2	4	5	4.3	5.6	4.7	6.2	5.3	6.6	6	6.9	6.5
	14					3.7	4.4	4.6	4.8	5.3	5.2	6	5.8	6.4	6.5	6.7	7
	16							4.4	5.2	5.2	5.6	5.8	6.2	6.3	7	6.6	7.4
	18									4.9	6.1	5.6	6.7	6.2	7.4	6.5	7.9
20									4.7	6.6	5.5	7.2	6	7.9	6.4	8.4	
280-40	2	9.7	1.4	10.2	1.7	10.5	1.9	10.8	2.3	11	2.7	11.2	3.4	11.3	4.1	11.4	4.6
	4	8.3	2.1	9.1	2.4	9.7	2.6	10.1	3	10.5	3.4	10.8	4	11	4.8	11.2	5.3
	6	7	2.8	8.2	3	8.9	3.3	9.6	3.7	10	4.1	10.4	4.7	10.7	5.5	10.9	6
	8	5.9	3.5	7.3	3.7	8.2	4	9	4.4	9.6	4.8	10.1	5.4	10.5	6.2	10.7	6.7
	10			6.5	4.4	7.6	4.7	8.5	5	9.2	5.5	9.8	6.1	10.2	6.9	10.6	7.4
	12					7	5.4	8.1	5.7	8.8	6.1	9.5	6.8	10	7.6	10.4	8.1
	14							7.6	6.4	8.5	6.8	9.3	7.5	9.8	8.2	10.2	8.8
	16									8.2	7.5	9.1	8.2	9.7	8.9	10.1	9.5
280-56	2	13.6	1.8	14.3	2	14.8	2.3	15.1	2.7	15.4	3.2	15.7	3.9	15.9	4.8	16	5.3
	4	11.7	2.8	12.8	3	13.6	3.3	14.2	3.7	14.7	4.2	15.1	4.9	15.4	5.7	15.6	6.3
	6			11.6	4	12.6	4.3	13.4	4.7	14.1	5.1	14.7	5.8	15.1	6.7	15.3	7.3
	8							12.7	5.6	13.5	6.1	14.2	6.8	14.7	7.7	15.1	8.2
	10									12.9	7.1	13.8	7.8	14.4	8.6	14.8	9.2
560-25	2	9.4	1.5	10	1.8	10.3	2.1	10.6	2.5	10.9	3	11	3.7	11.2	4.6	11.3	5.2
	4	7.9	2.2	8.8	2.5	9.4	2.8	9.9	3.2	10.2	3.7	10.6	4.4	10.8	5.3	11	5.9
	6	6.6	2.9	7.8	3.2	8.6	3.5	9.3	3.9	9.8	4.4	10.2	5.1	10.5	6	10.8	6.6
	8	5.3	3.6	6.9	3.9	7.9	4.2	8.7	4.6	9.3	5	9.9	5.8	10.3	6.7	10.6	7.2
	10			6	4.5	7.2	4.8	8.2	5.2	8.9	5.7	9.6	6.5	10	7.3	10.4	7.9
	12					6.5	5.5	7.7	5.9	8.5	6.4	9.3	7.1	9.8	8	10.2	8.6
	14					5.9	6.2	7.2	6.6	8.1	7.1	9	7.8	9.6	8.7	10	9.3
	16							6.9	7.3	7.9	7.8	8.8	8.5	9.4	9.4	9.9	10
	18							6.5	8	7.6	8.4	8.5	9.2	9.2	10.1	9.7	10.7
	20							6.1	8.6	7.2	9.1	8.3	9.9	9	10.7	9.6	11.3
	22									6.9	9.8	8.1	10.5	8.9	11.4	9.4	12
	24									6.6	10.5	7.8	11.2	8.7	12.1	9.3	12.7

**FTSH Performance Parameters**

The performance table of main technique

Speed n=950r/min

Size	ΔP (bar)	Viscosity (mm <sup>2</sup> /s)															
		1		15		35		75		150		350		750		1500	
		m <sup>3</sup> /h	KW	m <sup>3</sup> /h	KW	m <sup>3</sup> /h	KW	m <sup>3</sup> /h	KW	m <sup>3</sup> /h	KW	m <sup>3</sup> /h	KW	m <sup>3</sup> /h	KW	m <sup>3</sup> /h	KW
560-34	2	13.3	1.9	13.9	2.2	14.3	2.5	14.7	2.9	15	3.5	15.1	4.3	15.3	5.3	15.4	5.9
	4	11.5	2.8	12.5	3.1	13.2	3.4	13.8	3.9	14.2	4.4	14.6	5.2	14.9	6.2	15.1	6.8
	6	9.9	3.7	11.4	4	12.3	4.4	13.1	4.8	13.7	5.3	14.2	6.1	14.6	7.1	14.8	7.8
	8	8.5	4.7	10.3	5	11.5	5.3	12.4	5.7	13.1	6.3	13.8	7	14.3	8	14.6	8.7
	10			9.3	5.9	10.6	6.2	11.8	6.7	12.6	7.2	13.4	8	14	9	14.4	9.6
	12			8.3	6.8	9.9	7.1	11.2	7.6	12.2	8.1	13.1	8.9	13.7	9.9	14.1	10.5
	14					9.1	8.1	10.6	8.5	11.7	9	12.7	9.9	13.4	10.8	13.9	11.5
	16					8.7	9	10.3	9.4	11.5	10	12.5	10.8	13.3	11.8	13.8	12.4
	18							9.8	10.4	11.1	10.9	12.2	11.7	13.1	12.7	13.6	13.3
	20						9.4	11.3	10.7	11.8	12	12.6	12.8	13.6	13.5	14.3	
560-50	2	19.9	2.5	20.7	2.8	21.3	3.2	21.7	3.7	22.1	4.3	22.4	5.3	22.6	6.4	22.7	7.2
	4	17.5	3.8	19	4.2	19.9	4.6	20.6	5.1	21.2	5.7	21.7	6.6	22.1	7.8	22.3	8.5
	6	15.5	5.2	17.4	5.5	18.6	5.9	19.7	6.4	20.4	7.1	21.1	8	21.6	9.1	22	9.9
	8	13.6	6.6	16	6.9	17.5	7.3	18.8	7.8	19.7	8.4	20.6	9.4	21.2	10.5	21.7	11.3
	10	11.8	7.9	14.6	8.3	16.5	8.6	18	9.2	19.1	9.8	20.1	10.7	20.8	11.9	21.4	12.6
	12			13.4	9.6	15.4	10	17.1	10.5	18.5	11.2	19.6	12.1	20.5	13.2	21.1	14
	14					14.5	11.4	16.4	11.9	17.9	12.5	19.2	13.5	20.1	14.6	20.8	15.3
	16						16	13.3	17.5	13.9	18.9	14.8	19.9	16	20.6	16.7	
560-72	2	28.5	3.2	29.7	3.7	30.5	4.1	31.2	4.7	31.7	5.4	32.1	6.5	32.4	7.9	32.7	8.7
	4	25	5.2	27.1	5.6	28.4	6.1	29.6	6.7	30.4	7.4	31.2	8.5	31.7	9.8	32.1	10.7
	6			24.8	7.6	26.6	8	28.2	8.6	29.3	9.4	30.3	10.5	31	11.8	31.6	12.7
	8					25	10	26.9	10.6	28.2	11.3	29.5	12.4	30.4	13.8	31.1	14.6
	10							25.7	12.6	27.3	13.3	28.8	14.4	29.9	15.7	30.6	16.6
800-30	2	17.4	3	18.1	3.6	18.5	4.2	18.9	5.1	19.1	6.1	19.4	7.7	19.5	9.6	19.7	10.8
	4	15.5	4.2	16.7	4.8	17.4	5.4	18	6.3	18.4	7.3	18.8	8.9	19.1	10.8	19.3	12
	6	13.9	5.4	15.4	5.9	16.4	6.6	17.2	7.5	17.8	8.5	18.4	10.1	18.8	11.9	19.1	13.2
	8	12.4	6.5	14.3	7.1	15.5	7.8	16.5	8.6	17.3	9.6	18	11.2	18.5	13.1	18.8	14.4
	10	11	7.7	13.2	8.3	14.7	8.9	15.9	9.8	16.8	10.8	17.6	12.4	18.1	14.3	18.6	15.5
	12			12.2	9.5	13.9	10.1	15.3	11	16.3	12	17.2	13.6	17.9	15.5	18.3	16.7
	14			11.2	10.7	13.1	11.3	14.7	12.2	15.8	13.2	16.8	14.8	17.6	16.6	18.1	17.9
	16					12.7	12.5	14.3	13.3	15.5	14.4	16.6	15.9	17.4	17.8	18	19.1
	18					12	13.6	13.8	14.5	15.1	15.5	16.3	17.1	17.2	19	17.8	20.2
	20					11.4	14.8	13.3	15.7	14.7	16.7	16	18.3	17	20.2	17.6	21.4
	22							12.8	16.9	14.3	17.9	15.7	19.5	16.7	21.4	17.4	22.6
	24							12.4	18	14	19.1	15.5	20.6	16.5	22.5	17.3	23.8
800-40	2	23.5	3.5	24.4	4.1	24.9	4.8	25.3	5.7	25.6	6.8	25.9	8.5	26.1	10.5	26.3	11.8
	4	21.3	5.1	22.6	5.7	23.5	6.4	24.3	7.3	24.8	8.4	25.3	10.1	25.7	12.1	25.9	13.4
	6	19.3	6.6	21.1	7.3	23.3	8	23.3	8.9	24.1	10	24.8	11.6	25.2	13.6	25.6	15
	8	17.5	8.2	19.8	8.8	21.2	9.5	22.5	10.5	23.4	11.5	24.2	13.2	24.8	15.2	25.2	16.5
	10	15.7	9.8	18.5	10.4	20.2	11.1	21.7	12	22.8	13.1	23.8	14.8	24.5	16.8	25	18.1
	12			17.2	12	19.2	12.7	20.9	13.6	22.2	14.7	23.3	16.4	24.1	18.4	24.7	19.7
	14			16	13.6	18.3	14.2	20.2	15.2	21.6	16.2	22.9	17.9	23.8	19.9	24.4	21.3
	16					17.8	15.8	19.8	16.7	21.3	17.8	22.6	19.5	23.6	21.5	24.3	22.8
	18							19.2	18.3	20.8	19.4	22.3	21.1	23.3	23.1	24	24.4
	20							18.6	19.9	20.3	21	21.9	22.6	23	24.6	23.8	26

## FTSH Performance Parameters

The performance table of main technique

Speed n=950r/min

Size	ΔP (bar)	Viscosity (mm <sup>2</sup> /s)															
		1		15		35		75		150		350		750		1500	
		m <sup>3</sup> /h	KW	m <sup>3</sup> /h	KW	m <sup>3</sup> /h	KW	m <sup>3</sup> /h	KW	m <sup>3</sup> /h	KW	m <sup>3</sup> /h	KW	m <sup>3</sup> /h	KW	m <sup>3</sup> /h	KW
800-60	2	35.7	4.5	36.8	5.3	37.6	6	38.2	7.1	38.6	8.3	39	10.2	39.3	12.5	39.5	14
	4	32.7	6.9	34.5	7.6	35.7	8.4	36.7	9.4	37.4	10.6	38.1	12.6	38.6	14.8	38.9	16.3
	6	30	9.3	32.5	10	34.1	10.7	35.5	11.8	36.5	13	37.4	14.9	38	17.2	38.5	18.7
	8			30.6	12.3	32.6	13.1	34.3	14.1	35.5	15.4	36.7	17.3	37.5	19.5	38.1	21
	10			28.8	14.7	31.2	15.4	33.2	16.8	34.7	17.7	36	19.6	37	21.9	37.7	23.4
	12					29.9	17.8	32.2	18.8	33.9	20.1	35.4	22	36.5	24.2	37.3	25.7
	14					28.6	20.1	31.2	21.2	33.1	22.4	34.8	24.3	36	26.6	36.9	28.1
	16							30.7	23.5	32.6	24.8	34.5	26.7	35.8	28.9	36.7	30.4
800-80	2	46.3	5.6	48.1	6.4	49.3	7.2	50.3	8.4	51	9.8	51.7	11.9	52.1	14.4	52.5	16.1
	4	41.2	8.7	44.3	9.5	46.3	10.4	47.9	11.6	49.1	12.9	50.2	15	51	17.6	51.6	19.3
	6			40.9	12.7	43.6	13.5	45.9	14.7	47.5	16.1	49	18.2	50.1	20.7	50.8	22.4
	8					41.2	16.7	44	17.8	46	19.2	47.9	21.3	49.2	23.9	50.1	25.5
	10							42.2	21	44.6	22.3	46.8	24.5	48.4	27	49.5	28.7
1400-38	2	33.9	4	34.8	9	35.4	5.2	35.9	6.1	36.3	7.1	36.6	8.7	36.8	10.6	37	11.9
	4	31.3	6.2	32.8	11.2	33.8	7.5	34	8.3	35.3	9.3	35.7	10.9	36.3	12.8	36.6	14.1
	6	29	8.4	31.1	13.4	32.5	9.6	33.6	10.5	34.5	11.5	35.2	13.1	35.8	15	36.2	16.3
	8	26.9	10.6	29.5	15.6	31.2	11.9	32.7	12.7	33.7	13.7	34.7	15.3	35.3	17.2	35.8	18.5
	10	24.9	12.8	28	17.8	30.1	14.1	31.7	14.9	33	15.9	34.1	17.5	34.9	19.4	35.5	20.7
	12	23.1	15	26.6	20	28	16.3	30.9	17.1	32.3	18.2	33.6	19.7	34.5	21.6	35.1	22.9
	14					27.9	18.5	30	19.3	31.6	20.4	33.1	21.9	34.1	23.8	34.8	25.1
	16					27.3	20.7	29.6	21.5	31.3	22.6	32.8	24.1	33.9	26	34.7	27.7
	18					26.4	22.9	28.9	23.7	30.7	24.8	32.4	26.3	33.6	28.2	34.4	29.5
	20							28.2	25.9	30.1	27	32	28.5	33.2	30.4	34.1	31.7
	22							27.5	28.1	29.6	29.2	31.6	30.7	32.9	32.6	33.9	33.9
	24									29.1	31.4	31.2	32.9	32.6	34.8	33.7	36.1
1400-50	2	45.3	4.9	46.3	5.6	47	6.3	47.6	7.3	48	8.5	48.3	10.2	48.6	12.4	48.8	13.8
	4	42.3	7.8	44.1	8.5	45.2	9.2	46.2	10.2	46.9	11.4	47.5	13.1	48	15.2	48.3	16.7
	6	39.8	10.7	42.2	11.4	43.7	12.1	45	13.1	45.9	14.2	46.8	16	47.4	18.1	47.9	19.6
	8	37.4	13.6	40.4	14.3	42.3	15	43.9	16	45.1	17.1	46.2	18.9	46.9	21	47.5	22.4
	10			38.7	17.2	41	17.9	42.9	18.9	44.3	20	45.5	21.8	46.4	23.9	47.1	25.3
	12			37.1	20.1	39.7	20.8	41.9	21.8	43.5	22.9	45	24.7	46	26.8	46.7	28.2
	14					38.5	23.7	41	24.7	42.7	25.8	44.4	27.6	45.6	29.7	46.4	31.1
	16							40.5	27.6	42.3	28.7	44.1	30.5	45.3	32.6	46.2	34
	18							39.7	30.5	41.7	31.6	43.6	33.4	44.9	35.5	45.9	36.9
	20									41.1	34.5	43.1	36.3	44.6	38.4	45.6	39.8
1400-75	2	67.6	6.8	69.3	7.6	70.3	8.4	71.2	9.6	71.9	11	72.5	13.1	72.9	15.6	73.2	17.3
	4	63.1	11.1	65.9	11.9	67.6	12.8	69.1	14	70.2	15.3	71.2	17.5	71.9	20	72.4	21.7
	6	59.1	15.5	62.8	16.3	65.2	17.1	67.3	18.3	68.7	19.7	70.1	21.8	71	24.3	71.7	26
	8			60.1	20.6	63.1	21.5	65.6	22.7	67.4	24	68.7	26.1	70.2	28.7	71.1	30.4
	10			57.5	25	61	25.8	64	27	66.1	28.4	67.5	30.5	69.5	33	70.5	34.7
	12					59.1	30.2	62.5	31.3	64.9	32.7	66.2	34.8	68.8	37.4	69.9	39
	14							61	35.7	63.7	37.1	65.5	39.2	68.1	41.7	69.4	43.4
	16									63.1	41.4	64.5	43.5	67.7	46.1	69.1	47.7
1400-96	2	84.6	8.3	87.2	9.2	88.9	10.1	90.2	11.4	91.2	13	92.2	15.3	92.8	18.2	93.3	20
	4	77.5	13.9	81.8	14.7	84.6	15.7	86.9	17	88.6	18.6	90.2	20.9	91.3	23.7	92.1	25.6
	6					80.9	21.3	84	22.6	86.3	24.1	88.4	26.5	89.9	29.3	91	31.2
	8									84.2	29.7	86.8	32	88.7	34.6	90	36.7
	10									82.2	35.2	85.3	37.6	87.5	40.4	89.1	42.3

**FTSH Performance Parameters**

The performance table of main technique

Speed n=950r/min

Size	ΔP (bar)	Viscosity (mm <sup>2</sup> /s)															
		1		15		35		75		150		350		750		1500	
		m <sup>3</sup> /h	KW	m <sup>3</sup> /h	KW	m <sup>3</sup> /h	KW	m <sup>3</sup> /h	KW	m <sup>3</sup> /h	KW	m <sup>3</sup> /h	KW	m <sup>3</sup> /h	KW	m <sup>3</sup> /h	KW
2500-43	2	54	6.8	55.4	7.9	56.4	9	57.2	10.6	57.7	12.5	58.3	15.3	58.6	18.7	58.9	21
	4	50	10.3	52.4	11.4	53.9	12.5	55.3	14.1	56.3	16	57.1	18.8	57.8	22.2	58.2	24.5
	6	46.4	13.8	49.7	14.9	51.8	16	53.6	17.6	54.9	19.5	56.2	22.3	57	25.7	57.6	28
	8	43.1	17.3	47.2	18.4	49.9	19.5	52.1	21.1	53.7	23	55.2	25.8	56.3	29.3	57	31.5
	10	40.1	20.8	44.9	21.9	48.1	23.1	50.7	24.6	52.6	26.5	54.4	29.3	55.6	32.8	56.5	35
	12	37.1	24.3	42.7	25.4	46.3	26.6	49.3	28.1	51.5	30	53.6	32.9	55	36.3	56	38.5
	14	34.3	27.8	40.6	28.9	44.7	30.1	48.1	31.6	50.5	33.5	52.8	36.4	54.4	39.8	55.5	42
	16			39.4	32.4	43.7	33.6	47.3	35.1	49.9	37	52.4	39.9	54	34.3	55.3	45.5
	18			37.6	35.9	42.3	37.1	46.2	38.7	49	40.5	51.7	43.4	53.5	46.8	54.9	49
	20			35.9	39.4	40.9	40.6	45.1	42.2	48.2	44	51	46.9	53	50.3	54.5	52.5
	22					39.6	44.1	44.1	45.7	47.4	47.5	50.4	50.4	52.5	53.8	54.1	56.1
	24							43.1	49.2	46.5	51	49.8	53.9	52.1	57.3	53.7	59.6
2500-56	2	70.3	8.2	72.2	9.4	73.4	10.7	74.5	12.4	75.2	14.4	75.9	17.6	76.4	21.4	76.7	23.9
	4	65.1	12.8	68.2	13.9	70.3	15.2	72	17	73.3	19.7	74.4	22.2	75.2	25.9	75.8	28.4
	6	60.4	17.3	64.7	18.5	67.5	19.8	69.9	21.5	71.6	23.6	73.1	26.7	74.2	30.5	75	33
	8	56.2	21.9	61.5	23.1	65	24.4	67.9	26.1	70	28.1	71.9	31.3	73.3	35.1	74.3	37.6
	10	52.2	26.5	58.5	27.6	62.6	28.9	66	30.7	68.5	32.7	74.8	35.9	72.4	39.6	73.6	42.1
	12			55.7	32.2	60.4	33.5	64.3	32.2	67.1	37.3	69.8	40.4	71.6	44.1	73	46.7
	14					58.2	38	62.6	39.8	65.8	41.8	68.8	45	70.8	48.8	72.3	51.3
	16							62.6	39.8	65	46.4	68.2	49.6	70.4	53.3	72	55.8
	18									63.9	51	67.3	54.1	69.7	57.9	71.4	60.4
	20									62.8	55.5	66.5	58.7	69	62.5	70.9	64.9
2500-85	2	106.6	11.2	109.5	12.6	111.4	14.1	113	16.1	114.1	18.5	115.2	22.2	115.9	26.6	116.5	29.6
	4	98.5	18.1	103.3	19.5	106	21	109.2	23	111.1	25.4	112.9	29.1	114.2	33.6	115.1	36.5
	6	91.4	25.1	98	26.4	104	27.9	105.9	30	108.5	32.4	110.9	36.1	112.6	40.5	113.8	43.4
	8			93.1	33.4	102.3	34.9	102.3	36.9	106.1	39.3	109.1	43	111.2	47.4	112.7	50.3
	10					98.4	41.8	100	43.8	103.8	46.2	107.4	49.9	109.9	54.3	111.7	57.3
	12					94.8	45.2	97.3	50.8	101.7	53.2	105.8	56.9	108.6	61.3	110.7	64.2
	14									99.6	60.1	104.2	63.8	107.4	68.2	109.7	71.1
	16									98.5	67	103.4	70.7	106.7	75.1	109.2	78.1
2500-112	2	141.2	14.1	144.9	15.7	147.2	17.4	149.2	19.8	150.6	22.6	152	26.9	152.9	32	153.5	35.4
	4	131.1	23.2	137.2	24.8	141.2	26.5	144.5	28.9	146.9	31.7	149.1	36	150.7	41.1	151.8	44.5
	6			130.5	33.9	135.9	35.7	140.4	38	143.6	40.8	146.6	45.1	148.8	50.2	150.3	53.6
	8							136.6	47.2	140.6	49.9	144.4	54.2	147	59.4	148.9	62.8
	10									137.8	59.1	142.2	63.4	145.3	68.5	147.5	71.9
4200-50	2	98.4	13.1	100.2	15.4	101.4	17.8	102.4	21.1	103.1	25	103.7	31.1	104.2	38.2	104.5	43
	4	93.3	19.3	96.4	21.6	98.3	24	100	27.3	101.2	31.2	102.3	37.2	103.1	44.4	103.7	49.2
	6	88.9	25.5	93	27.8	95.7	30.2	97.9	33.5	99.6	37.4	101.1	43.4	102.1	50.6	102.9	55.4
	8	84.8	31.7	89.9	33.9	93.3	36.4	96	39.7	98.1	43.6	99.9	49.6	101.3	56.8	102.2	61.6
	10	81	37.9	87	40.1	90.9	42.6	94.3	45.5	96.6	49.8	98.9	55.8	100.4	63	101.5	67.7
	12	77.3	44.1	87.3	46.3	88.8	48.8	92.6	52.1	95.3	56	97.9	62	99.6	69.2	100.9	73.9
	14	73.8	50.3	81.6	52.5	86.7	54.9	91	58.3	94	62.1	96.9	68.2	98.9	75.4	100.3	80.1
	16	71.9	56.4	80.2	58.7	85.6	61.1	90	64.4	93.3	68.3	96.3	74.4	98.5	81.5	100	86.3
	18	68.9	62.6	77.9	64.5	83.8	67.3	88.7	70.6	92.2	74.5	95.5	80.1	97.8	87.7	99.5	92.5
	20			75.7	71.1	82	73.5	87.3	76.8	91.1	80.7	94.7	86.7	97.2	93.9	99	98.7
	22					80.3	79.7	86	83	90.1	86.9	93.9	92.9	96.6	100.1	98.5	104.9
	24							84.7	89.2	89.1	93.1	93.1	99.1	96	106.3	98	111.1

## FTSH Performance Parameters

The performance table of main technique

Speed n=950r/min

Size	ΔP (bar)	Viscosity (mm <sup>2</sup> /s)															
		1		15		35		75		150		350		750		1500	
		m3/h	KW	m3/h	KW	m3/h	KW	m3/h	KW	m3/h	KW	m3/h	KW	m3/h	KW	m3/h	KW
4200-67	2	132	16	134	18	136	21	137	24	138	28	139	34	139	42	140	47
	4	125	24	129	26	132	29	134	32	135	36	137	43	138	50	139	55
	6	120	32	125	35	128	37	131	44	133	45	135	51	137	59	138	64
	8	114	40	121	43	125	45	129	49	131	53	134	59	135	67	137	72
	10	109	49	117	51	122	54	126	57	130	61	132	68	134	75	136	80
	12	105	57	114	59	119	62	124	65	128	70	131	76	133	83	135	88
	14	100	65	110	68	117	70	122	74	126	78	130	84	132	92	134	97
	16			108	76	115	79	121	82	125	86	129	92	132	100	134	105
	18			106	84	113	87	119	90	124	94	128	101	131	108	133	113
20					111	95	118	99	122	103	127	109	130	117	133	122	
4200-100	2	194	20	198	23	201	25	203	29	205	34	206	40	207	48	208	54
	4	182	33	189	35	194	38	197	42	200	46	203	53	205	61	206	66
	6	171	45	181	47	187	50	193	54	196	58	200	65	203	73	204	79
	8	162	57	174	60	181	63	188	66	193	71	197	77	200	86	203	91
	10	153	70	167	72	176	75	184	79	189	83	195	90	198	98	201	103
	12			160	85	171	87	180	91	186	95	192	102	197	110	200	116
	14					166	100	176	103	183	108	190	115	195	123	198	128
16							174	116	182	120	189	127	189	135	197	104	
4200-128	2	242	24	249	27	254	30	257	34	260	39	262	46	262	55	265	61
	4	223	40	235	43	242	46	248	50	253	55	257	62	257	74	262	77
	6	207	56	222	59	232	62	241	66	247	71	252	78	252	87	259	93
	8	191	72	211	75	223	78	234	82	241	87	248	94	248	103	257	109
	10			200	91	214	74	227	98	236	102	244	110	244	119	254	124
7000-80	2	244	35	245	20	246	22	246	22	247	25	248	30	248	35	248	42
	4	232	47	233	35	235	38	235	38	236	45	237	54	237	63	238	75
	6	222	57	225	47	226	50	226	50	228	67	230	74	230	90	231	102
	8	212	70	215	57	218	60	218	60	221	85	223	98	223	113	225	127
	10	200	80	205	71	210	75	210	75	213	103	215	120	215	136	217	153
	12	185	86	193	82	200	86	200	86	205	118	208	137	208	156	210	177
	14			185	100	192	105	192	105	200	133	203	153	203	176	205	197
	16			176	110	184	117	184	117	189	147	192	170	192	193	195	217
	18					170	128	170	128	179	157	172	180	172	205	175	230
	20					153	135	162	135	165	160	168	182	168	208	172	233
	22							148	140	150	164	154	184	154	210	160	237
	24							123	145	127	168	130	186	130	213	140	240
7000-100	2	310	25	312	25	313	27	313	27	314	32	316	37	316	43	320	52
	4	292	42	294	42	295	45	295	45	297	58	300	68	300	77	302	90
	6	282	57	284	57	285	60	285	60	287	83	290	96	290	110	292	125
	8	270	72	273	73	275	77	275	77	277	106	280	124	280	141	283	160
	10	258	86	262	87	265	82	265	82	268	130	270	150	270	170	273	190
	12	248	100	252	102	255	107	255	107	258	150	260	173	260	197	263	220
	14			235	124	238	130	238	130	246	167	250	193	250	220	253	247
	16			218	136	223	145	223	145	233	187	235	213	235	242	238	270
	18					216	162	215	162	227	200	230	228	230	260	233	293
	20					197	167	208	167	210	220	212	233	212	266	215	300
7000-128	2	393	30	396	31	398	33	398	33	400	40	402	47	402	55	405	66
	4	376	52	380	53	382	55	382	55	385	75	387	87	387	100	390	110
	6	363	72	366	73	370	75	370	75	375	107	377	125	377	141	380	160
	8	350	92	354	94	358	97	358	97	362	138	365	160	365	183	368	207
	10	333	110	338	112	343	115	343	115	355	167	358	193	358	220	360	247
	12	320	128	324	130	330	135	330	135	333	193	336	224	336	256	340	287
	14			300	160	310	166	310	166	313	213	316	246	316	280	320	317
16					280	193	280	193	285	233	290	270	290	306	295	347	

**FTSH Performance Parameters**

The performance table of main technique

Speed n=950r/min

Size	ΔP (bar)	Viscosity (mm <sup>2</sup> /s)															
		1		15		35		75		150		350		750		1500	
		m <sup>3</sup> /h	KW	m <sup>3</sup> /h	KW	m <sup>3</sup> /h	KW	m <sup>3</sup> /h	KW	m <sup>3</sup> /h	KW	m <sup>3</sup> /h	KW	m <sup>3</sup> /h	KW	m <sup>3</sup> /h	KW
7000-150	2	473	37	476	38	478	40	478	40	483	48	484	57	484	68	488	80
	4	443	62	448	64	450	66	450	66	455	88	456	103	456	118	460	135
	6	406	85	414	88	418	90	418	90	425	124	427	145	427	165	430	187
	8	380	107	388	110	392	113	392	113	395	160	402	186	402	213	405	240
	10	333	128	346	130	350	135	350	135	360	193	370	224	370	253	375	290
7000-160	2	507	40	510	42	512	44	513	45	515	54	517	62	519	70	521	78
	4	477	76	481	80	484	84	486	86	487	102	490	118	493	134	497	149
	6	440	105	448	111	453	118	457	121	458	144	460	167	463	188	467	210
	8	413	131	421	140	428	149	427	150	429	180	431	208	435	236	440	264
	10	367	146	380	158	390	169	397	175	400	210	403	244	408	276	413	310
9800-80	2	367	49	369	54	371	59	372	65	373	73	374	81	374	87	375	97
	4	359	70	362	75	365	80	367	86	369	95	370	102	371	108	372	118
	6	352	91	356	96	359	102	362	108	365	116	367	123	368	129	369	139
	8	345	112	350	117	355	123	358	129	361	137	364	145	365	150	367	160
	10	339	133	345	138	350	144	354	150	358	158	361	166	362	172	365	181
	12	333	154	340	159	346	165	350	171	355	179	358	187	360	193	362	203
	14	327	175	335	180	341	186	347	192	352	200	355	208	357	214	360	224
	16	322	197	330	201	337	207	343	213	349	221	353	229	355	235	358	245
	18	316	218	326	222	334	228	340	234	346	242	350	250	353	256	356	266
	20			321	244	330	249	336	255	343	263	348	271	351	277	354	287
	22					326	270	333	276	340	285	345	292	348	298	352	308
	24					323	292	330	298	338	306	343	313	346	319	351	329
9800-100	2	441	58	443	64	445	70	447	77	448	87	449	96	450	103	451	115
	4	431	83	434	89	438	96	440	103	443	112	444	121	445	128	447	140
	6	442	109	427	114	431	121	434	128	438	138	440	147	442	154	443	165
	8	413	134	419	140	425	146	429	153	433	163	436	172	438	179	440	191
	10	405	159	413	165	419	172	427	179	429	188	433	198	435	204	437	216
	12	398	185	406	190	414	197	419	204	425	214	429	223	432	230	435	241
	14	391	210	400	216	409	223	415	230	421	239	426	248	429	255	432	297
	16	384	236	394	241	404	248	411	255	418	264	426	274	426	281	430	292
	18			389	267	399	273	406	280	414	290	420	299	423	306	427	318
	20			383	292	394	299	402	306	411	315	417	324				
	22				389	324	398	331	407	341							
	24				385	349	394	356									
9800-128	2	513	67	516	74	519	81	521	89	523	100	524	111	525	119	526	132
	4	500	97	505	103	509	111	512	119	515	130	518	141	519	148	521	162
	6	489	126	495	133	501	141	505	149	509	160	512	170	514	178	517	191
	8	478	156	486	162	493	170	495	178	504	189	507	200	510	208	513	221
	10	468	186	478	192	486	200	492	208	495	219	503	229	505	237	509	251
	12	459	215	469	222	479	229	486	238	493	248	498	259	501	267	506	280
	14	450	245	462	251	472	259	480	267	488	278	494	289	495	297	502	310
	16			454	281	466	289	475	297	484	308	490	318	494	326	499	340
	18			447	311	460	318	470	326	479	337						
	20					454	348	464	356								
	22																
	24																
9800-150	2	660	87	664	95	667	105	669	115	672	129	673	143	674	153	676	170
	4	643	125	649	133	654	143	658	153	663	168	665	181	667	191	669	209
	6	628	163	636	171	644	181	649	191	655	206	659	219	661	229	664	247
	8	615	201	625	209	634	219	641	230	647	244	652	257	655	267	659	285
	10	602	239	614	247	624	257	632	268	641	282	646	295	650	306	654	323
	12	590	277	603	285	616	295	625	306	634	320	641	333	645	344	650	361
	14			593	323	607	333	617	344	628	358						
9800-160	2	708	70	717	79	723	89	727	103	731	118	733	138	735	156	736	173
	4	684	111	699	121	708	131	716	144	721	160	726	180	729	197	731	214
	6	663	158	682	163	695	172	706	186	714	201	720	221	723	239	726	256
	8	643	195	667	204	683	214	697	227	707	243	714	263	719	280	722	297
	10	625	238	653	245	673	256	688	269	700	285	709	305	714	322	718	339
	12	607	280	641	289	662	298	680	311	693	327	704	346	710	364	714	381

## FTSH Performance Parameters

The performance table of main technique

Speed n=950r/min

Size	ΔP (bar)	Viscosity (mm <sup>2</sup> /s)															
		1		15		35		75		150		350		750		1500	
		m <sup>3</sup> /h	KW	m <sup>3</sup> /h	KW	m <sup>3</sup> /h	KW	m <sup>3</sup> /h	KW	m <sup>3</sup> /h	KW	m <sup>3</sup> /h	KW	m <sup>3</sup> /h	KW	m <sup>3</sup> /h	KW
18000-176	0	1133		1167		1187		1200		1210		1213		1217		1220	
	2	1020	74	1097	85	1115	91	1152	99	1161	109	1165	119	1193	133	1195	143
	4	963	140	1050	161	1068	173	1104	129	1113	209	1116	229	1144	254	1147	275
	6	906	200	1003	233	1021	243	1056	259	1065	279	1068	301	1095	335	1098	350
	8	850	250	969	301	985	312	1020	333	1029	360	1031	387	1055	431	1061	451
	10			933	359	949	369	984	391	992	413	995	434	1022	487	1025	508
	12					925	432	960	457	968	484	971	509	998	570	1001	595
	16					902	561	936	594	944	629	947	661	973	741	976	775
18000-192	0	1233		1267		1301		1333		1347		1353		1357		1360	
	2	1110	81	1191	91	1223	99	1280	109	1293	121	1299	133	1329	148	1333	159
	4	1049	153	1140	175	1171	190	1227	210	1239	233	1245	255	1275	283	1297	306
	6	987	217	1089	253	1119	266	1173	287	1185	311	1191	335	1221	374	1224	390
	8	925	257	1051	327	1080	342	1133	370	1145	400	1151	433	1180	482	1183	503
	10			1013	382	1041	401	1093	434	1104	460	1110	485	1139	543	1143	567
	12					1015	469	1067	508	1077	539	1083	567	1113	636	1115	664
	16					989	615	1040	660	1051	701	1055	737	1085	827	1088	863
18000-224	0	1500		1533		1567		1600		1613		1620		1623		1627	
	2	1350	112	1440	118	1473	123	1533	131	1547	144	1553	159	1590	171	1593	184
	4	1273	214	1380	227	1410	239	1473	252	1487	277	1490	305	1527	327	1530	353
	6	1200	310	1320	327	1347	334	1407	345	1420	369	1427	397	1460	431	1463	448
	8	1123	400	1273	423	1300	431	1360	445	1373	476	1377	511	1413	556	1417	578
	10			1227	495	1253	505	1313	521	1323	547	1327	573	1380	625	1383	651
	12					1207	592	1280	610	1293	640	1297	671	1330	732	1333	762
	16					1191	777	1248	793	1259	832	1263	872	1299	951	1301	991
18000-250	0	1667		1700		1720		1733		1747		1753		1757		1760	
	2	1500	125	1600	128	1633	135	1664	142	1677	156	1697	171	1720	185	1723	199
	4	1417	239	1530	245	1563	259	1593	272	1607	299	1627	327	1650	353	1650	381
	6	1333	337	1460	355	1497	365	1527	374	1537	400	1558	430	1580	467	1583	486
	8	1250	433	1410	457	1445	469	1473	484	1483	515	1503	553	1527	602	1530	626
	10			1360	535	1393	549	1420	563	1433	591	1460	620	1493	676	1497	704
	12					1359	643	1387	660	1400	693	1420	727	1440	792	1443	825
	16					1307	833	1347	855	1360	898	1380	940	1403	1027	1407	1069







FTSW Series Twin Screw Pmp

Authorized Distributor